

ANSI/IEEE Std 120-1989

(Revision of IEEE Std. 120-1955
and ASME PTC 19.6-1955)

An American National Standard

IEEE Master Test Guide for Electrical Measurements in Power Circuits

Sponsor

**Power Systems Instrumentation and Measurements Committee
of the
IEEE Power Engineering Society**

Approved May 22, 1989

IEEE Standards Board

Approved October 20, 1989

American National Standards Institute

© Copyright 1989 by

**The Institute of Electrical and Electronics Engineers, Inc
345 East 47th Street, New York NY 10017-2394, USA**

No part of this publication may be reproduced in any form, in an electronic retrieval system or otherwise, without the prior written permission of the publisher.

IEEE Standards documents are developed within the Technical Committees of the IEEE Societies and the Standards Coordinating Committees of the IEEE Standards Board. Members of the committees serve voluntarily and without compensation. They are not necessarily members of the Institute. The standards developed within IEEE represent a consensus of the broad expertise on the subject within the Institute as well as those activities outside of IEEE which have expressed an interest in participating in the development of the standard.

Use of an IEEE Standard is wholly voluntary. The existence of an IEEE Standard does not imply that there are no other ways to produce, test, measure, purchase, market, or provide other goods and services related to the scope of the IEEE Standard. Furthermore, the viewpoint expressed at the time a standard is approved and issued is subject to change brought about through developments in the state of the art and comments received from users of the standard. Every IEEE Standard is subjected to review at least once every five years for revision or reaffirmation. When a document is more than five years old, and has not been reaffirmed, it is reasonable to conclude that its contents, although still of some value, do not wholly reflect the present state of the art. Users are cautioned to check to determine that they have the latest edition of any IEEE Standard.

Comments for revision of IEEE Standards are welcome from any interested party, regardless of membership affiliation with IEEE. Suggestions for changes in documents should be in the form of a proposed change of text, together with appropriate supporting comments.

Interpretations: Occasionally questions may arise regarding the meaning of portions of standards as they relate to specific applications. When the need for interpretations is brought to the attention of IEEE, the Institute will initiate action to prepare appropriate responses. Since IEEE Standards represent a consensus of all concerned interests, it is important to ensure that any interpretation has also received the concurrence of a balance of interests. For this reason IEEE and the members of its technical committees are not able to provide an instant response to interpretation requests except in those cases where the matter has previously received formal consideration.

Comments on standards and requests for interpretations should be addressed to:

Secretary, IEEE Standards Board
P.O. Box 1331
445 Hoes Lane
Piscataway, NJ 08855-1331
USA

IEEE Standards documents are adopted by the Institute of Electrical and Electronics Engineers without regard to whether their adoption may involve patents on articles, materials, or processes. Such adoptions does not assume any liability to any patent owner, nor does it assume any obligation whatever to parties adopting the standards documents.
--

Foreword

(This Foreword is not a part of IEEE Std 120-1989, IEEE Master Test Guide for Electrical Measurements in Power Circuits.)

This updated version is based on the material submitted for the abandoned 1981 draft plus material submitted during the 1985–87 reinstatement of Working Group 120.

The basic approach for the new organization is to provide general guidelines intended to assist nonelectrical engineers and technicians involved in quality control, acceptance, and prototype testing where electrical instrumentation is the main tool for measuring, observing, or recording physical quantities.

The contributors strived to reflect in the new text the many improvements and novel techniques developed in modern instrumentation in the last decades.

A list of complete definitions characterizing voltage/current waves generated or injected by modern converters is provided.

Digital meters are presented in the context of all the measurements described in this standard when applicable.

Since the new instrumentation based on digital logic is most sensitive to electromagnetic noise, special sections, 1.7 and 1.8, were dedicated to grounding and shielding.

This updated edition also contains the following new material:

- Chapter 6, Measurements of Magnetic Quantities in Power Circuits
- Section 7.1, Transducers
- Section 7.2, Oscilloscopes
- Section 7.3, Analog Recorders
- Section 7.4, Power Supplies
- Section 8.1, Computer-Based Techniques
- Section 8.2, Optical Fibers in Instrumentation

The membership of the 1985/7 Working Group 120 is as follows:

A. E. Emanuel, *Chair*
D. McAuliff (*Editorial Coordinator*)

Chapter Coordinators

Chapter 1: W. J. M. Moore
Chapter 2: O. Petersons
Chapter 3, 6, 8: A. E. Emanuel
Chapters 4, 5, 7: D. McAuliff

Other Contributors:

S. W. Crampton
L. T. Fitch
A. A. Girgis

R. Hopkins
F. J. Levitsky
D. C. McDonald
N. M. Oldham

R. W. Shoemaker
E. So
R. H. Stevens

The following persons were on the balloting committee that approved this document for submission to the IEEE Standards Board:

A. Abramowitz
S. A. Annestrand
J. M. Belanger
J. M. Carr
G. Carrara
S. W. Crampton
F. C. Creed
A. E. Emanuel
R. E. Hebner
R. Hopkins
P. B. Jacob, Jr.

W. E. Keagle, Jr.
J. A. Kise
S. R. Knudsen
F. R. Kotter
J. Kuffel
F. J. Levitsky
R. Malewski
D. McAuliff
T. R. McComb
R. H. McKnight
W. J. M. Moore

J. H. Moran
D. Mukhedkar
O. Petersons
R. Reid
P. H. Reynolds
W. E. Rich
R. L. Richardson
H. M. Schneider
E. So
J. M. Vanderleck
D. L. Whitehead

When the IEEE Standards Board approved this standard on May 22, 1989, it had the following membership:

Dennis Bodson, *Chair*
Marco W. Migliaro, *Vice Chair*
Andrew G. Salem, *Secretary*

Arthur A. Blaisdell
Fletcher J. Buckley
Allen L. Clapp
James M. Daly
Stephen R. Dillon
Donald C. Fleckenstein
Eugene P. Fogarty
Jay Forster*
Thomas L. Hannan

Kenneth D. Hendrix
Theodore W. Hissey, Jr.
John W. Horch
David W. Hutchins
Frank D. Kirschner
Frank C. Kitzantides
Joseph L. Koepfinger*
Edward Lohse

John E. May, Jr.
Lawrence V. McCall
L. Bruce McClung
Donald T. Michael*
Richard E. Mosher
Stig Nilsson
L. John Rankine
Gary S. Robinson
Donald W. Zipse

*Member Emeritus

CLAUSE	PAGE
1. Chapter 1—General	1
1.1 Purpose.....	1
1.2 Scope.....	1
1.3 Units.....	1
1.4 Definitions.....	2
1.5 Waveform Parameters (see Table 1-1).....	3
1.6 Operating Principles of Measuring Instrument.....	7
1.7 Grounding	11
1.8 Magnetic and Capacitive Interferences and Their Reduction	13
1.9 Terms and Definitions for Performance Evaluation of a Measurement Process or Instrument	17
1.10 Transportation	20
1.11 Safety	20
1.12 Bibliography.....	20
2. Chapter 2—Voltage and Current Measurements	22
2.1 Introduction.....	22
2.2 Voltage Measurements.....	22
2.3 Current Measurements	29
2.4 Instrument Transformers.....	34
2.5 Bibliography.....	45
3. Chapter 3—Power, Energy, and Power Factor	46
3.1 Power Measurement.....	46
3.2 Energy Measurements.....	54
3.3 Power Factor and Phase-Angle Measurement	58
3.4 Transducers	59
3.5 Bibliography.....	59
4. Chapter 4—Frequency Measurements	60
4.1 Description	60
4.2 Methods of Measuring Frequency	60
4.3 Calibration.....	62
5. Chapter 5—Impedance Measurements	63
5.1 Description	63
5.2 Determination of Impedance.....	63
5.3 Effective Resistance.....	63
5.4 Effective Reactance.....	64
5.5 Difficulties Encountered in Making Measurements	64
5.6 Bridge Methods.....	65
5.7 Bibliography.....	66
6. Chapter 6—Measurements of Magnetic Quantities in Power Circuits	67
6.1 Description	67
6.2 Measurements in Air.....	67
6.3 Measurements in Electromagnets	69

CLAUSE	PAGE
6.4 Measurements in Permanent Magnets	69
6.5 Measurements of B , Φ , and H in Samples of Magnetic Materials.....	70
6.6 Measurement of Permeability in Electrical Steels or Magnet Iron.....	70
7. Chapter 7—Ancillary Instruments and Equipment.....	71
7.1 Electrical Transducers.....	71
7.2 Oscilloscopes	74
7.3 Analog Recording Meters and Devices	78
7.4 Power Supplies.....	81
7.5 Bibliography.....	86
8. Chapter 8—New Technology	87
8.1 Computer-based Techniques.....	87
8.2 Optical Fibers in Instrumentation	91
8.3 Bibliography.....	92

IEEE Master Test Guide for Electrical Measurements in Power Circuits

1. Chapter 1—General

1.1 Purpose

It is the purpose of this guide to give instructions for those measurements of electrical quantities that are commonly needed in determining the performance characteristics of electric machinery and equipment. The choice of the measurement method and instrument systems to be used depends on the purpose of the measurement, the accuracy required, the time and testing equipment available, and the nature of the circuit.

1.2 Scope

The methods given here relate to measurements, as made with either analog or digital indicating or integrating instruments, of power, energy, voltage, and current, in dc or ac rotating machines, transformers, induction apparatus, arc and resistance heating equipment, mercury arc, thermionic, or solid-state rectifiers and inverters. Measurements made with supplementary instruments and devices are also included. This guide does not deal with measurements of resistance or temperature that are often included in determining the performance characteristics of electric machinery. Instruments for these latter measurements will be found in the specific publications dealing with the particular measurement, such as IEEE Std 118-1978, IEEE Standard Test Code for Resistance Measurements [4]¹, and IEEE Std 119-1974, IEEE Recommended Practice for General Principles of Temperature Measurement as Applied to Electrical Apparatus [5].

1.3 Units

The measurement of any electrical quantity is the comparison of that quantity with another quantity of the same kind that has been chosen as a unit. The fundamental or basic electrical units are based on the International System of Units (SI), which is a modern version of the MKSA (meter, kilogram, second, ampere) system. For further details see ansi/ieec 268-1982, IEEE Standard for Metric Practice [3]. In magnetic measurements it is the common practice to use the cgs (centimeter-gram-second) system. The instrument readouts are frequently in the cgs units. Hence, in Chapter 6 of this guide both units are used and a conversion table is provided.

¹The numbers in brackets correspond to those of the bibliography at the end of this chapter.

1.3.1 International System of Units

The units of the electrical quantities are as follows:

Quantity	Name of SI Unit	Symbol
Electric potential, potential difference, tension, electromotive force	volt	V
Electric current	ampere	A
Electric charge (quantity)	coulomb	C
Power	watt	W
Energy	joule (watt-second)	J
Capacitance	farad	F
Inductance	henry	H
Frequency	hertz	Hz
Resistance	ohm	Ω

1.4 Definitions

1.4.1 RMS Value:

$$y_{\text{rms}} = \left[\frac{1}{T} \int_a^{a+T} y^2 dt \right]^{1/2}$$

where y_{rms} is the root-mean-square (rms) value of y , y is an instantaneous value of a period function, a is any instant of time, and T is the period.

The rms value of a periodic waveform may also be expressed as the square root of the sum of the squares of the Fourier components of y .

$$y_{\text{rms}} = [A_1^2 + A_2^2 + \dots + A_n^2]^{1/2}$$

where A_1, A_2, A_n are the rms values of the fundamental component, second harmonic, and n th harmonic, respectively.

1.4.2 Average Absolute Value:

$$y_{\text{AAV}} = \frac{1}{T} \int_a^{a+T} |y| dt$$

where y_{AAV} is the average absolute value (often called simply the average) of y , a is any instant of time, and T is the period.

1.4.3 Peak Value: The peak value y_p is the largest absolute value of y .

1.4.4 Form Factor: The form factor (ff) of a periodic function is the ratio of the rms value to the average absolute value

$$ff = y_{\text{rms}}/y_{\text{AAV}}$$

1.4.5 Crest Factor: The crest factor (cf) of a periodic function is the ratio of the peak value to the rms value

$$cf = y_p/y_{\text{rms}}$$

1.4.6 Distortion Factor: The distortion factor df is defined as

$$df = \left[\sum_{k=2}^n \frac{A_k^2}{A_1^2} \right]^{1/2}$$

where A_1 is the rms value of the fundamental component and A_2 to A_n are the rms values of the harmonic components.

1.4.7 Deviation Factor: The deviation factor is the ratio of the maximum difference between corresponding ordinates of the wave and of the equivalent sine wave to the maximum ordinate of the equivalent sine wave when the waves are superposed in such a way as to make this maximum difference as small as possible. The equivalent sine wave is defined as having the same frequency and the same rms value as the wave being tested.

1.4.8 Apparent (Phasor) Power: $S = VI$

where S is the apparent power, V is the rms value of the voltage, and I is the rms value of the current.

1.4.9 Average Active Power:

$$P = \frac{1}{T} \int_{t_0 - T/2}^{t_0 + T/2} p \, dt$$

where P is the average active power at any time t_0 , $p = vi$ is the instantaneous power, v and i are the instantaneous values of voltage and current, and T is the period.

If both the voltage and current are sinusoidal and of the same period, P is given by

$$P = VI \cos \theta$$

where V and I are the rms values of voltage and current respectively and θ is the phase angle separating V and I .

The general expression for polyphase active power in a system with m phases and n harmonics involves a summation over all harmonics in accordance with the above equation and a summation over all phases.

1.4.10 Reactive Power: The reactive power Q is defined as the square root of the square of the apparent power S minus the square of the active power P .

$$Q = (S^2 - P^2)^{1/2}$$

Reactive power is developed when there are inductive, capacitive, or nonlinear elements in the system. It does not represent useful energy that can be extracted from the system but it can cause increased losses and excessive voltage peaks.

1.5 Waveform Parameters (see Table 1-1)

1.5.1 Sine Wave

$$y_{\text{rms}} = \left[\frac{1}{T} \int_0^T (y_p \sin \omega t)^2 dt \right]^{1/2} = \frac{y_p}{\sqrt{2}} = 0.7071 y_p$$

where $\omega\tau = 2\pi$

$$y_{\text{AAV}} = \left[\frac{1}{T} \int_0^T y_p |\sin \omega t| dt \right] = \frac{2y_p}{\pi} = 0.6366 y_p$$

$$ff = \frac{y_p}{\sqrt{2}} / \frac{2y_p}{\pi} = \frac{\pi}{2\sqrt{2}} = 1.1107$$

$$cf = y_p / \frac{y_p}{\sqrt{2}} = 1.4142$$

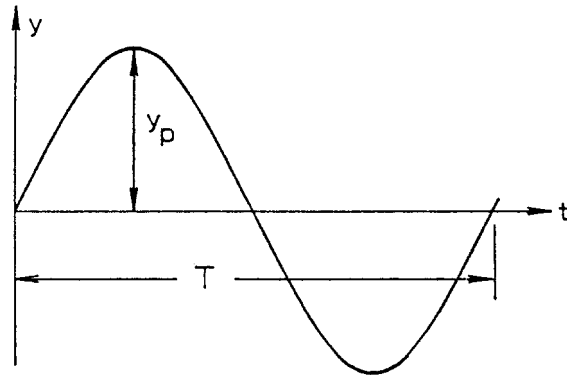

1.5.2 Square Wave

$$y_{\text{rms}} = y_{\text{AAV}} = y_p$$

$$ff = cf = 1$$

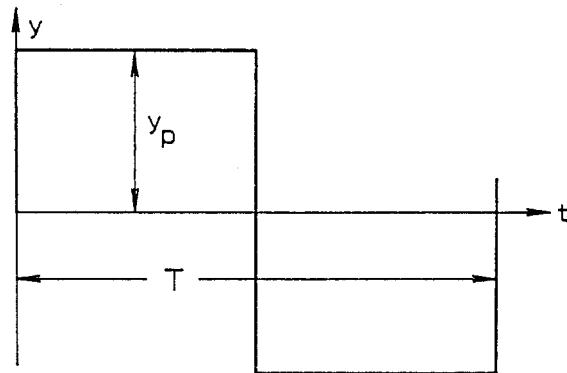

1.5.3 Triangular Wave

$$y_{\text{rms}} = \left[y_p^2 \int_0^{T/4} \left(\frac{4}{T}t \right)^2 dt \right]^{1/2} = \frac{y_p}{\sqrt{3}} = 0.5774y_p$$

$$y_{\text{AAV}} = y_p \int_0^{T/4} \frac{4}{T}t dt = 0.5y_p$$

$$ff = \frac{0.5774y_p}{0.5y_p} = 1.1548$$

$$cf = \frac{y_p}{0.5774y_p} = 1.7319$$

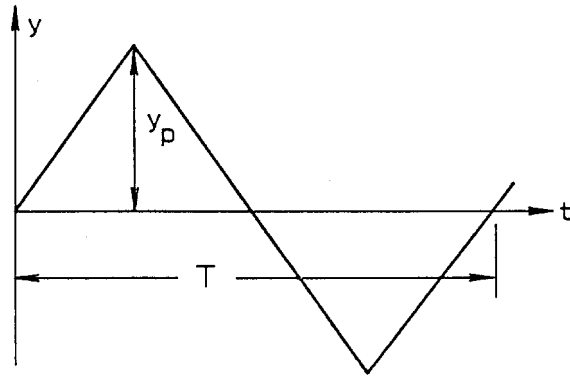

1.5.4 Sine Wave Distorted with 30% Third Harmonic Shifted by θ

(This is the waveform influence test specified in the ANSIC39 series [2].)

$$y_{\text{rms}} = \left[\left(\frac{y_p}{\sqrt{2}} \right)^2 + \left(\frac{0.3y_p}{\sqrt{2}} \right)^2 \right]^{1/2} = 0.7382y_p$$

$$y_{\text{AAV}} = \frac{y_p}{T} \int_0^T |\sin \omega t + 0.3 \sin(3\omega t + \theta)| dt$$

$$= \frac{y_p}{\pi} [2 + 0.2 \cos \theta]$$

$$= \frac{2.2y_p}{\pi} = 0.7003y_p$$

(for $\theta = 0^\circ$, maximum AAV)

$$= \frac{1.8y_p}{\pi} = 0.573y_p$$

(for $\theta = 180^\circ$, minimum AAV)

where $\omega T = 2\pi$ and y_p is the peak value of the fundamental component,

$$ff(\theta = 0^\circ) = \frac{0.7382}{0.7003} = 1.0541$$

$$cf(\theta = 0^\circ) = 1.2460$$

$$ff(\theta = 180^\circ) = 1.2883$$

$$cf(\theta = 180^\circ) = 1.7610$$

Table 1-1—Waveform Parameters

Waveform	rms	AAV	Peak	ff	cf
Sine wave	$0.707 y_p$	$0.637 y_p$	y_p	1.111	1.414
Square wave	y_p	y_p	y_p	1	1
Sine wave + 30% 3rd Harmonic (in phase- 0°)	$0.738 y_p^*$	$0.700 y_p^*$	$0.920 y_p^*$	1.054	1.246
Sine wave + 30% 3rd Harmonic (180°)	$0.738 y_p^*$	$0.573 y_p^*$	$1.300 y_p^*$	1.288	1.762
Triangular wave	$0.577 y_p$	$0.500 y_p$	y_p	1.155	1.732
SCR (90° firing angle)	$0.354 y_p$	$0.318 y_p$	y_p	1.111	2.828

* y_p is the peak value of the fundamental component of the measured signal.

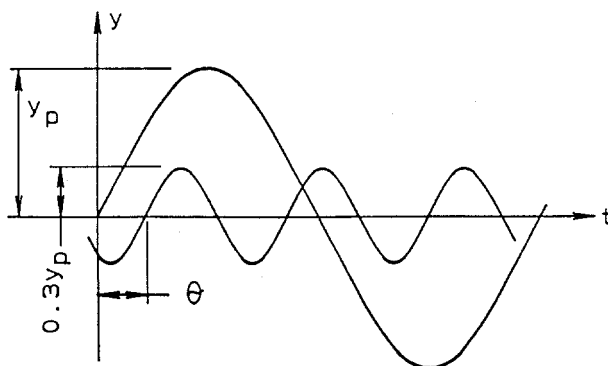

1.5.5 SCR Switched Sine Wave (90% Firing Angle)

$$y_{\text{rms}} = 0.3536 y_p$$

$$y_{\text{AAV}} = 0.3183 y_p$$

$$ff = 1.1109$$

$$cf = 2.8281$$

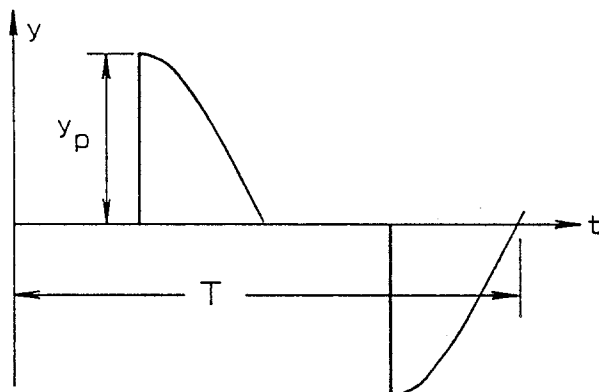

1.6 Operating Principles of Measuring Instrument

In this section, the operating principles of numerous types of measuring instruments are briefly described. More complete descriptions are provided where appropriate in other sections of this guide.

1.6.1 Measurement of Average Voltage and Current

The average value of a periodic signal is obtained by integrating the instantaneous value y over k periods (where k is an integer 1, 2, ...).

$$y_{AVE} = \frac{1}{kT} \int_0^{kT} y \, dt$$

This is normally done using a capacitor-type integrator. A wide variety of both passive and active circuits is in use. Since the integral of a symmetrical alternating signal (over one period) is zero, the averaging circuit gives only the dc component of the waveform.

1.6.2 Measurement of Average Absolute Value

The average absolute value (AAV) is a more useful parameter that is obtained by rectifying the signal before integration. Circuits ranging from simple diode bridges to operational-amplifier-aided rectifiers and integrators are commonly used in analog and digital indicating instruments.

The scales of such instruments can be, and are, usually marked to indicate the rms value of a sinusoidal signal. With sinusoidal waveforms, accuracies of about 0.1–1.0% can be achieved in the measurement of the rms values. With nonsinusoidal waveforms, the errors can be large.

1.6.3 Measurement of Peak Value and Quasi-Peak Value

Peak reading instruments indicate the maximum value of a waveform during a given measurement period. The peak value is obtained by rectifying the signal and storing its maximum value on a capacitor. This value is sensed, without appreciably discharging the capacitor, with a high-impedance averaging voltmeter.

If the capacitor is coupled with a charging resistor and a discharging resistor, a type of quasi-peak-sensing circuit is obtained. If both the charging and discharging time constants are long in relation to the period of the signal to be measured, the response of the quasi-peak circuit is independent of the signal frequency. By adjusting the ratio of the two resistors, any value of rectified periodic signal can be sensed—from its peak value to a value that approaches zero.

1.6.4 Phase-Sensitive Detector

In the diode-switched phase-sensitive detector, a reference voltage, V_r , biases a pair of diodes in such a way that the signal voltage, V_s , is gated during a half cycle of V_r . The average value of the gated signal is given by

$$kV_s \cos\theta$$

where θ is the phase angle separating V_r and V_s and k is a proportionality constant.

The use of active elements to idealize the diodes has greatly improved the performance of this circuit, yielding accuracies of the order of 0.1–1.0% under sinusoidal conditions.

If the voltages are nonsinusoidal, large errors are possible. With a nonsinusoidal signal voltage and a sinusoidal reference voltage, the errors are similar to those of the AAV-sensing, rms-indicating meter mentioned in 1.6.2. Distortion in the reference voltage can be proportional to a current yielding a phase-sensitive ammeter or current transducer.

1.6.5 Square Law Devices and Signal Multipliers

From definition 1.4.1, the rms value of a periodic function is the square root of the square of the instantaneous value averaged over one period. In order to implement this definition in an electrical measuring instrument, a circuit element that responds to the square of the input waveform is required. Similarly, average power is obtained by averaging the instantaneous product of voltage and current over an integral number of cycles, according to 1.4.9. A circuit element that responds to the product of two inputs is required. Multiplication and square law response may be achieved in a number of ways as described in the following sections.

1.6.5.1 Electrostatic Instruments

These instruments consist of a set of fixed and moving electrodes (plates or disks) that are insulated from each other forming a capacitor capable of storing charge. The instantaneous stored energy (w) is given by

$$w = \frac{1}{2}v^2C$$

where v is the instantaneous voltage between the plates and C is the capacitance. The torque due to the attraction between the electrodes is

$$\tau = \frac{dw}{d\theta}$$

and the restoring torque (supplied by the spring) is proportional to the angular displacement θ . If the time constant of the mechanical system is long compared with the period of the applied torque, the deflection of the indicator is a function of the rms voltage:

$$k\theta = \frac{1}{2}V^2\frac{dC}{d\theta}$$

where V is the rms value of voltage, and k is a constant. If $dC/d\theta$ is constant, the deflection of the indicator (θ) is a quadratic function of V . The scales on the instruments are marked to indicate V , thus in effect computing the square root. In the allowable frequency band, the indication is not affected by the waveform. By combining the electrostatic voltmeter with a shunt, an ammeter can be realized. With a more complex instrument, power can be measured. Electrostatic instruments, although capable of 0.25–1.0% accuracy, are rarely used in modern measurement applications, except those at high voltages.

1.6.5.2 Electrodynamic Instruments

Such devices consist of a set of fixed and moving coils that carry currents that are proportional to the quantities to be measured. The energy stored in the magnetic field of the coils is given by

$$w = \frac{i_1^2 L_1}{2} + \frac{i_2^2 L_2}{2} + i_1 i_2 M$$

where i and L are the currents and inductances associated with each coil, and M is the mutual inductance between coils. The torque between the coils may be written as

$$\tau = \frac{dw}{d\theta} = i_1 i_2 \frac{dM}{d\theta}$$

since L_1 and L_2 are not functions of θ . Electro-dynamic instruments, when calibrated with dc, are capable of accuracies better than 0.1% under laboratory condition and better than 1.0% in the field. They are still in use, particularly in the power industry. The general considerations are analogous to those of the electrostatic meter. In the allowable

frequency band, the indication is not affected by the waveform. With appropriate resistors and shunts, electrodynamic instruments can be configured to measure rms currents, voltage, and average power.

1.6.5.3 Thermal Instruments

Thermal instruments operate by measuring the temperature rise, τ , of a heater wire carrying the current, i . The instantaneous power, p , dissipated in the heater resistance, R , is

$$p = i^2 R$$

If the thermal time constant is long in relation to the time constant of the electrical signal, if R is constant, and if the heat loss is proportional to the temperature rise,

$$\Delta_{(\text{temp})} = kI^2$$

where I is the rms current and k is a proportionality constant. Within the allowable frequency band, the heater temperature rise is a function of the rms value of the current and is not affected by the waveform.

The temperature is normally measured by a thermocouple that has its hot junction in thermal contact with the heater and its cold junction near room temperature. Vacuum thermoelements (having the heater and thermocouple enclosed in an evacuated tube) are capable of accuracies exceeding 0.01% when used as transfer devices in standards laboratory environments. In this mode the thermocouple output is brought to the same voltage on ac and dc. The dc value corresponds to the rms value of the ac signal, eliminating the need for precise square law response. More recently, monolithic devices using thin film heaters, temperature sensing transistors, and amplifiers have been developed and built into digital voltmeters. The accuracies are in the 0.01–0.1% range.

Average active power may be sensed with a pair of thermoelements using a quarter-square technique. A small current proportional to the voltage is combined with a portion of the test current, i , in the following manner:

$$P_{\text{AVG}} = \frac{k}{T} \int_0^T [(v+i)^2 - (v-i)^2] dt = \frac{4k}{T} \int_0^T vi dt$$

The passive implementation of the thermal wattmeter is capable of accuracies exceeding 0.5%. Higher accuracies, to 0.01%, and faster response times are possible when the thermoelements are combined with operational amplifiers and used as ac/dc transfer devices.

1.6.5.4 Transconductance Multipliers

In the variable-transconductance multiplier, one input controls the gain of an active device such as a silicon junction transistor that amplifies the other input. The relationship between the collector current, I_c , and the base-emitter voltage V_{be} is given by

$$\Delta I_c = k I_c \cdot \Delta V_{be}$$

where k is a proportionality constant.

Transconductance multipliers can achieve accuracies of 0.1–1.0% over the audio frequency range. If I_c and V_{be} are derived from the same input, transconductance multipliers can be used as accurate square law circuit elements in rms voltmeters and ammeters. Wattmeters are implemented by deriving I_c and V_{be} , from the test current and test voltage, respectively.

1.6.5.5 Time-Division Multipliers

Time-division multipliers or pulse modulation multipliers generate pulses that are controlled in amplitude by one input and in width by the other. The average area under these rectangular pulses is proportional to the product of the two inputs. As with transconductance multipliers, time division multipliers can be configured as rms voltmeters and ammeters or as wattmeters. Errors of 0.01-0.1% can be achieved over the multiplier bandwidth. Since these devices effectively sample the waveform, they are limited to the measurement of frequency components that are less than the Nyquist frequency (one half the pulse or sampling frequency).

1.6.5.6 Waveform Digitizing

Waveform digitizing combined with digital calculation is one of the newest techniques currently finding application in commercial instrumentation. In this approach the voltage and current waveforms are simultaneously sampled and digitized with an analog-to-digital converter. RMS values (voltage or current) are obtained by averaging the squares of the instantaneous value of either waveform over an integral number of periods and then extracting the square root of the average

$$y_{\text{rms}} = \left[\frac{1}{n} \sum_{k=1}^n y_k^2 \right]^{1/2}$$

The average power can be calculated in a similar manner by averaging the product of the instantaneous voltage and current

$$P = \frac{1}{n} \sum_{k=1}^n v_k i_k$$

1.6.5.7 Logarithmic Amplifier

Logarithmic amplifier circuit elements use a grounded base transistor as a feedback element in a standard inverting operational amplifier circuit. With the transistor emitter connected to the output of the amplifier and the collector to the summing node, the output, v_o is related to the input, V_{in} , by the following relationship

$$v_o = k \ln \frac{v_{in}}{R}$$

where R is the input resistance and k is a proportionality constant. The antilog operation is obtained by interchanging the positions of the input resistor and the log element (transistor).

Multiplication is obtained by summing the output of two log stages driven from different sources, while powers and roots can be generated by adjusting the gain of the log and antilog stages. The square-root capability of the log circuit element is particularly important in rms measurements for extracting the root of the mean-squared signal, thus allowing the use of linear scale displays.

1.6.5.8 Diode-Type Function Generators

Square-law approximation using multiple diodes is achieved by altering the voltage to current relationship in segments (e.g., as the voltage crosses preselected thresholds, diodes switch in different resistances which change the current slope). The rms error in the approximation is inversely proportional to the square of the number of equally spaced segments, N , produced by $N-1$ diodes

$$\varepsilon = \frac{0.38}{N^2}$$

By optimizing segment length (i.e., using shorter segments in the areas of greatest curvature), fewer segments may be needed to achieve a given accuracy. Between four and five diodes are required to approximate quadratic response to within 1%. Square root response can also be approximated which, when combined with an averaging filter, provides linear scale rms indication.

As with the thermal wattmeter, quarter-square techniques can be used to convert the square-law diode array to a multiplier for measuring active power.

1.6.5.9 Hall Effect Multiplier

In Hall effect multipliers a magnetic field, B , proportional to the test voltage, v , is applied at right angles to the test current, i , in a semiconductor. A voltage v_H , which is perpendicular to both B and i , is developed across the semiconductor

$$v_H = k Bi$$

where k is a proportionality constant.

Hall multipliers are generally configured as wattmeters and power transducers in the 0.5-1% accuracy class.

1.7 Grounding

Many instruments have three input terminals, marked high, low, and ground or +, -, and \perp . Others have four terminals, +, - common, and ground. The terminal marked ground, or \perp , is the safety ground; all external metal parts of the instrument are connected to this point, which in turn is connected to the ground lead of the ac utility power line. In proper installations the ground connection will prevent hazardous potentials from developing between adjacent metallic enclosures and between enclosures and building ground. This assures that none of the conducting parts of the instrument that the user could touch can rise in potential above the safe margin (42 V) with respect to ground. A metal link is often provided between the common terminal (sometimes the low terminal) and the ground. The common point is then grounded. Measuring errors may occur where other instruments or devices under test in the same system have also a connection to ground. (See ground loops.) In such situations the common terminal and the ground terminal must be disconnected. Nevertheless, the instrument's cabinet chassis or ground terminal must remain connected to ground.

Clear distinction should be made between the common and ground; under normal operating conditions, a common is intended to carry current, while a ground is not. Grounds must be designed to carry fault current under abnormal conditions.

Minimum ground wire size and general safety practices should comply with ANSI C2-1990, American National Standard National Electrical Safety Code [1].

1.7.1 Ground Loops

When two points in a measuring system are connected to the ground, a ground loop is formed. Ground loops should be considered in the layout of the measurement circuit as they can cause erroneous measurement results.

An example of a ground loop formed between a grounded transducer and a measuring instrument grounded at a different location is shown in Fig 1-1. The impedance Z_1 represents the transducer impedance, Z_2 and Z_2^1 are the impedances of the conductors that connect the two devices, and Z_{1m} is the instrument impedance. The transducer might be an ac-power-to-dc-voltage transducer, a thermocouple, an accelerometer, or any electrical-to-electrical or

mechanical-to-electrical transducer. V_s is the transducer output voltage. The instrument can be a digital or analog indicating meter, an oscilloscope, an impedance bridge, or any type of data acquisition device.

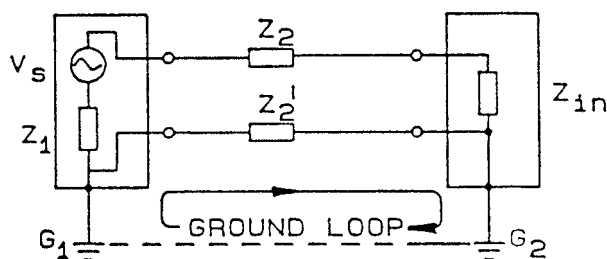

Figure 1-1—Ground Loop

1.7.2 Common-Mode and Series-Mode Voltages

A common-mode voltage is the voltage between a common point, usually the point at which the instrument is grounded, and both conductors connected to the input terminals of the instrument. A series-mode or normal-mode voltage is the voltage in series with the two input terminals of the instrument. In the presence of ground loops, a common-mode voltage can couple into the measurement circuit so as to appear as a series-mode voltage.

A common-mode voltage, V_{cm} , is shown in Fig 1-2. A voltage between two physical grounding points, G_1 and G_2 , may exist as a result of currents in the ground or grounded conductors. Such ground currents could be caused by unbalanced load currents in the 3-phase system and by unbalanced line-to-ground capacitive currents. The common-mode voltage in turn introduces currents in the measuring circuit and an erroneous series-mode voltage, V_{sm} , that is added to the output voltage of the transducer.

With $V_s = 0$, the voltage across Z_{in} becomes

$$V_{sm} = V_{cm} \left[\frac{Z_1 + Z_2}{Z_1 + Z_2 + Z_{in}} - 1 \right]$$

For $Z_2 \ll Z_1$, $Z_2 < Z_{in}$, and $Z_1 \ll Z_{in}$

$$V_{sm} = -V_{cm}$$

In the above example, the common-mode voltage effectively becomes the series-mode voltage and is measured by the instrument. V_{cm} is a noise in the presence of the signal, V_s , that is being measured.

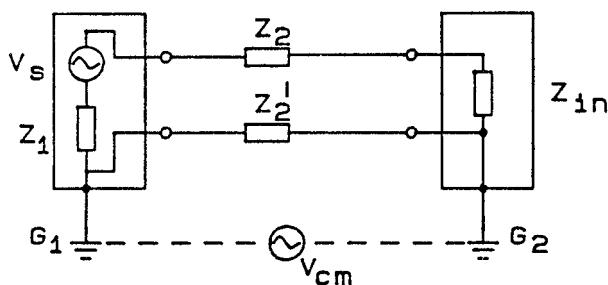

Figure 1-2—Common-Mode Voltage

To avoid the generation of series-mode voltage, the system should be grounded only at one point, e.g., (1) by connecting the ground terminals of the instrument and the transducer to one physical ground point, (2) by grounding the entire instrument and the enclosure of the transducer as shown in Fig 1-2, but by disconnecting the grounded end of the transducer proper from its enclosure. The transducer itself is then grounded at the measuring instrument and through the lead impedance Z_1^2 . In any grounding modification, the safety aspects should not be compromised.

1.7.3 Remedial Methods

In many measurement systems multiple grounding and the resulting common-mode voltages cannot be avoided and remedial techniques should be used. Popular remedial methods are shown in Fig 1-3, and they involve isolation transformers, bifilar or coaxial inductors (chokes), instrumentation amplifiers, and optocouplers.

1.8 Magnetic and Capacitive Interferences and Their Reduction

Even if the ground current and associated common-mode voltages, as discussed in 1.7.2, are eliminated by grounding the system at a single point, erroneous signals can still be introduced in the measuring circuit from the nearby power system and other sources by magnetic and capacitive couplings. The elements of such coupling and the methods for their reduction are discussed.

1.8.1 Magnetic Coupling

Magnetic coupling is illustrated in Fig 1-4(a). An error voltage, V_{sm} , equivalent to the series-mode voltage of 1.7.2 is introduced in the measurement circuit by the current I in the power conductor above the measuring circuit. The current in this conductor produces a magnetic field. A portion of the resulting magnetic flux links the measuring circuit and introduces an error voltage

$$V_{sm} = 2\pi f \Phi$$

where Φ is the magnetic flux that links the measuring circuit, and f is the frequency of the magnetic field. This error voltage can be represented by an equivalent generator as in Fig 1-4(b). The size of the loop, the proximity and orientation of the power conductor relative to the measuring circuit, and the magnitude of I determine the magnitude of V_{sm} .

1.8.2 Capacitive Coupling

Capacitive or electrostatic coupling is illustrated in Fig 1-5(a). The capacitive current, I_{c1} and I_{c2} , from the power conductor, could introduce an erroneous “series-mode” voltage. This voltage can be calculated from the circuit of Fig 1-5(a) leading to a somewhat complicated expression. The calculation can be simplified by removing the negligible terms, such as products of capacitive current and lead impedances. Under those assumptions I_{c2} has no effect. Usually Z_1 , is much smaller than Z_{in} and thus nearly all of I_{c1} passes through Z_1 . The resultant series-mode voltage is given by

$$V_{sm} = V 2\pi C_1 Z_1$$

The equivalent circuit showing V_{sm} is given in Fig 1-5(b).

1.8.3 Coaxial and Twisted Leads

The problems of magnetic and capacitive couplings as illustrated in Figs 1-4 and 1-5 can be eliminated by the use of a coaxial connecting cable. Such a cable has no net loop to capture extraneous magnetic flux such as Φ in Fig 1-4. The outer conductor of a coaxial cable is connected to the ground. It shields electrostatically the inner conductor and thus eliminated I_{c1} in Fig 1-5.

If the connecting cable is a twisted pair of conductors, the net loop to capture the flux Φ is reduced by creating a large number of small loops in which alternatively positive and negative voltages are induced thus nearly eliminating any net erroneous voltage. The twisted pair does not eliminate capacitive coupling but may reduce it.

1.8.4 Shielding Techniques

Cables discussed in 1.8.3 may not suffice for eliminating undesirable magnetic and capacitive couplings, and additional shielding of the measuring circuit might be necessary. For example, exposed components in the transducer or the instrument could become the points of pickup of undesirable signals. At high frequencies, including fast surges, the cables that suffice at dc or low frequencies may become inadequate. While the shielding over a wide frequency band is an involved subject beyond the scope of this guide, several guidelines are of particular importance in the power system.

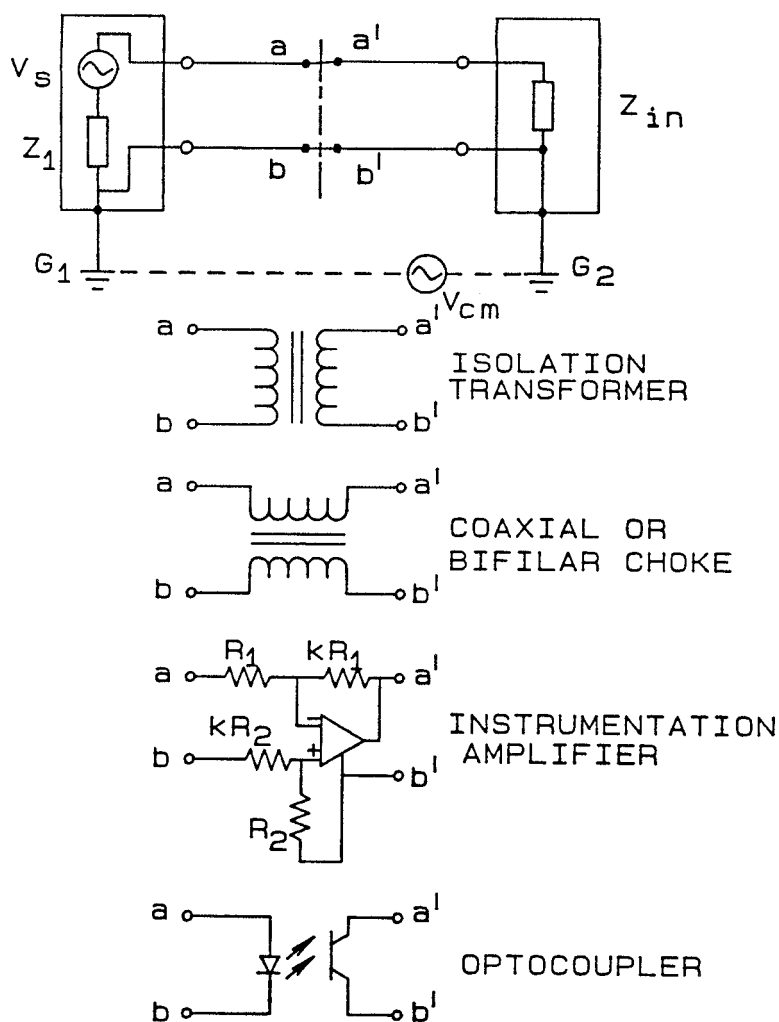

Figure 1-3—Methods for Elimination of Adverse Effects of Group Loops

Electrostatic fields produce not only interference in the measurement but may also permanently damage solid-state electronic components. A properly grounded metal housing provides the most effective means of shielding against such fields. For low frequency investigations, such a housing can be made of sheet metal, foil, or braid. Near perfect electrostatic shielding can be achieved for fully enclosed parts.

Nonmagnetic metal enclosures with thin walls, such as those made of sheet metal, are ineffective as low-frequency magnetic shields. In order to become effective, the wall thickness of the enclosure must be of the same order as or larger than the penetration depth of the electromagnetic field for the particular shielding material. Effective low-frequency magnetic shields made of conductive material must be constructed so as not to impede the paths for the eddy currents.

High-permeability ferromagnetic materials are the best shielding materials against dc and low-frequency magnetic fields. An effective magnetic shield should have low reluctance/high permeability material, large cross-sectional area material, and a short path for the flux that is to be shielded against. Shields having simple geometries, such as spheres and long cylinders, have simple expressions for the shielding ratios at dc and at low frequencies. For cylindrical enclosures (magnetic field perpendicular to the axis of the cylinder)

$$\frac{B_I}{B_0} = \frac{2r}{d\mu}$$

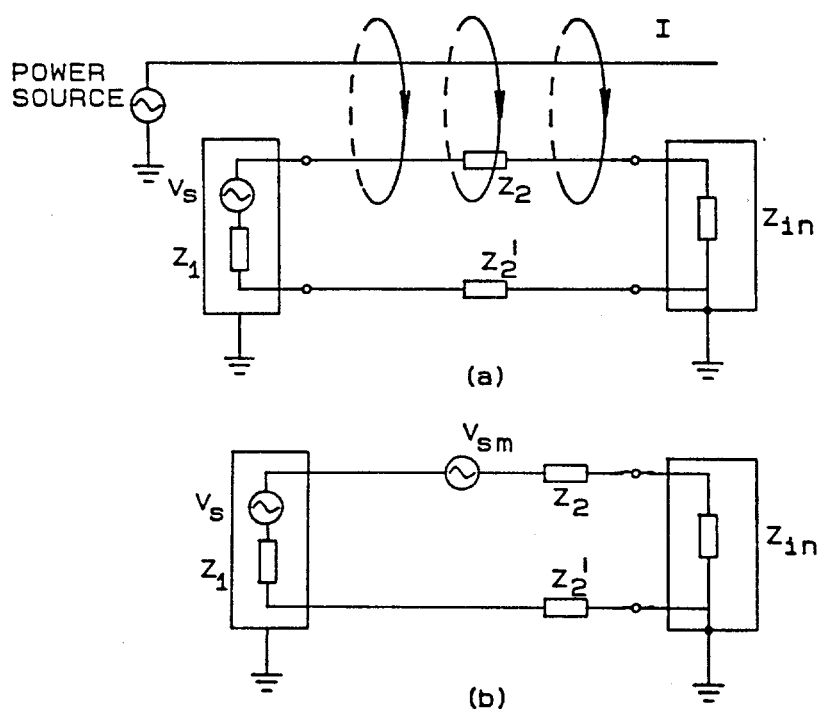

Figure 1-4—(a) Magnetic Coupling (b) Equivalent Circuit Showing Series-Mode Voltage

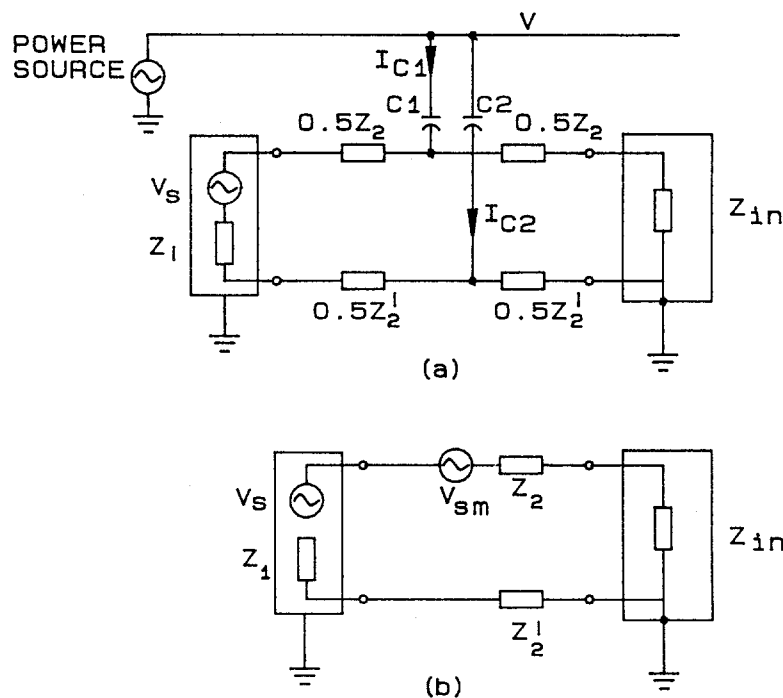

Figure 1-5—(a) Capacitive Coupling (b) Equivalent Coupling

For spherical enclosures

$$\frac{B_I}{B_0} = \frac{3r}{2d\mu}$$

where

- B_I = the magnetic flux density inside the enclosure
- B_0 = the unperturbed uniform flux density without the shield
- d = the wall thickness of the enclosure
- r = the radius of the enclosure
- μ = the permeability of the shielding material relative to air

Care should be exercised in constructing the high-permeability magnetic shields in order to avoid discontinuities and increased reluctances in critical paths for the magnetic flux. To achieve the highest permeabilities, the materials may have to be annealed after constructing the enclosure. High level of magnetic shielding is much more difficult to achieve than of electrostatic shielding. A high permeability magnetic shielding enclosure made of metal sheet has sufficient conductivity and thus will serve adequately also as an electrostatic shield.

In high-frequency electromagnetic waves, both electric and magnetic field components must be considered. Near perfect shielding as in the low-frequency electrostatic case cannot be readily achieved in practical enclosures because of limited thickness of the shielding material and because of discontinuities such as joints, openings, and power supply leads, all of which facilitate penetration by electromagnetic fields.

A cylindrical shield is illustrated in Fig 1-6.

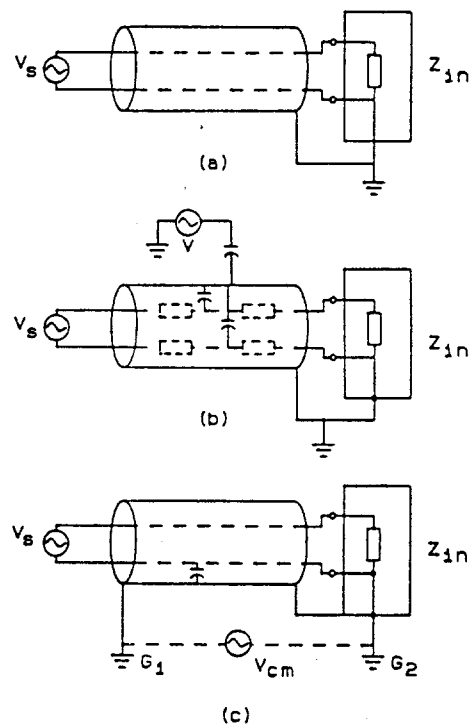

Figure 1-6—(a) Shielding of Conductors (b) imperfect Shielding Caused by Finite Lead and Shield Impedances (c) Incorrect Grounding of Shield

In 1-6(a) a shield, e.g., braid, surrounds a pair of conductors. If magnetic shielding is also required, a high-permeability tube can be used at dc or at low frequencies.

In Fig 1-6(b) a condition is illustrated where a finite shield and lead impedances and shield-to-conductor capacitances cause noise to be coupled to the signal leads. Figure 1-6(c) illustrates multiple grounding of a shielded circuit whereby the ground current in the shield and the shield-to-conductor capacitance could introduce error in the measuring circuit. A single ground, if permissible under safety considerations, is preferable.

For more detailed information on grounding, shielding, and noise reduction, refer to the following literature:

IEEE Std 518-1982, IEEE Guide for the Installation of Electrical Equipment to Minimize Electrical Noise Inputs to Controllers from External Sources [6].

R. Morrison. *Grounding and Shielding Techniques in Instrumentation*, (3rd edition). New York: John Wiley & Sons, 1986 [7].

H.W. Ott. *Noise Reduction Techniques in Electronic Systems*. New York: John Wiley & Sons, 1976 [8].

1.9 Terms and Definitions for Performance Evaluation of a Measurement Process or Instrument

The process of measurement is to determine the true value of a quantity by measurement. In practice this goal is never achieved, only approached. No measurement, however carefully made, can be completely free of uncertainties. To evaluate the performance of a measurement process or instrument requires the understanding and definition of such terms as error, correction, uncertainty, accuracy, precision, resolution, threshold, sensitivity, linearity, and offset.

1.9.1 Error and Correction: Error is the quantity difference between the value obtained from the measurement process or indicated by the instrument employed in the measurement process and the true value. Since the actual magnitude of the error is unknown and cannot be known, the measured value minus the estimated error is only an approximation to the true value.

The performance of the measurement process or instrument is quite often defined in terms of the limits of error. The limits of error implies that the measured value lies within the bounds prescribed by the limits of error and is usually expressed as percentage of full scale value or percentage of reading.

Several kinds of errors exist. Some are readily evaluated, others may only be estimated. The errors are generally classified as systematic and random.

Systematic errors cause the measured value to be displaced or biased a fixed amount. If these errors are known through a calibration process, their effect can be eliminated by correction factors. However quite often their magnitude and direction are not known, or are known only partly, and, therefore, only estimated limits of systematic error can be made.

Random errors have random causes that will force several independent measurements of a quantity to be distributed randomly about their average value. The average or arithmetic mean is usually assumed to be the “most probable value” or “best estimate value” of the measured quantity. For n observations x_1, x_2, \dots, x_n it may be expressed as

$$\bar{x} = \frac{x_1 + x_2 + \dots + x_n}{n} = \frac{\sum x_n}{n}$$

Standard deviation is a measure of the dispersion from the mean. It is defined as the rms of the deviations of a set of observations from the arithmetic mean of the set and is expressed as

$$s_x = \sqrt{\frac{\sum d_n^2}{n-1}}$$

where s_x is the standard deviation, d_n is the deviation of any individual observation from the mean of the set, that is $(x_n - \bar{x})$ and n is the number of observations in the set.

If a second set of n measurements were recorded, the second value of the mean would in general differ from the first value. But the difference between the two means would be expected to be less than the standard deviation in either set. The best measure of the uncertainty of the final answer $x_{\text{best}} = \bar{x}$ is the standard deviation s_x divided by \sqrt{n} . This quantity is called the standard deviation of the mean, and is denoted $s_{\bar{x}}$:

$$s_{\bar{x}} = \frac{s_x}{\sqrt{n}}$$

Other common names for this are standard error and standard error of the mean. A multiplying factor or a t -factor, that is $t s_{\bar{x}}$ where t is any positive number, may be used to modify the standard deviation of the mean to increase the limits or error, and the probability that the new mean will be within the increased limits. This multiplying factor or t -factor is usually associated with a confidence level that is a measure of the probability that the new mean will be within the increased limits. For example, for a normal distribution, the probability that a measurement, x_{best} , will fall inside $3 s_{\bar{x}}$ is 99.7%.

If the data from a finite number of measurements were plotted on a graph of value versus frequency of occurrence of each value, a profile could be faired through the plotted points. As the number of measurements approaches infinity, their distribution approaches some definite, continuous curve. If the data stems from completely random effects, the curve will be a symmetrical bell-shaped curve with the mean value as the center of the curve. This curve is known as the normal or Gaussian distribution curve. The confidence level or percentage probability of occurrence is calculated from the distribution function or can be obtained from a table in a book on statistics.

Correction is the quantity that must be added algebraically to the measured value to obtain the true value. It is opposite in sign to error.

1.9.2 Uncertainty: The uncertainty of a measurement is the interval about the quoted value in which the actual or true value of the unknown is believed to lie. An uncertainty is associated with the result because one can never exactly determine the measurement error. The uncertainty is thus the interval of a probable range of the error in the measurement.

Total uncertainty and limits of error are both used to give an indication of measurement accuracy. These terms are occasionally used in the technical literature interchangeably. Limits of error implies an absoluteness; total uncertainty does not. The total uncertainty of a measurement is a function of both systematic and random errors. The standard deviation of the mean can be regarded as the random component of the total uncertainty. For example, the total uncertainty of a measurement can be stated as the estimated limits of the systematic error, plus t times the standard deviation of the mean for random errors. The multiplying factor depends on the chosen level of confidence. Depending on the conditions and end use of the results, the total uncertainty can also be expressed in terms of the root-sum-square of the two error components.

1.9.3 Accuracy: Accuracy is the degree of closeness that the measured value approaches the true value, the deviation of the measured value from the true value being an accuracy index.

1.9.4 Precision: Precision is a measure of consistency or repeatability. It is related to the random error and expresses the variation between individual measurements of the same quantity. The index of precision is stated in terms of deviation of a single observation or a group of observations from a mean value. Precision, however, does not consider systematic errors and thus does not guarantee accuracy.

1.9.5 Resolution: Resolution is the degree to which a measurement system or instrument can detect the smallest change of a quantity starting from a non-zero value of the quantity. Resolution is not constant but is dependent on test conditions.

1.9.6 Threshold: Threshold is the largest repeatable absolute value of the minimum input change to which can be assigned a unique value of the change of expected output whenever the measurement system or instrument is used in a prescribed, repeatable measurement situation.

1.9.7 Sensitivity: Sensitivity is a measure of instrument effectiveness and is usually defined as the ratio of the output change to input change, that is, the unit output corresponding to the unit input under static conditions. In instruments with strong nonlinearities, no single number can be given as the “sensitivity” of the instrument.

1.9.8 Linearity: The linearity of a measurement system or instrument is a property expressing the condition wherein the change in the value of one quantity or input is directly proportional to the change in the value of another quantity or output. It describes a constant ratio of incremental cause and effect.

1.9.9 Offset: Zero offset is the output of a measurement system or indication of an instrument for an input equal to zero.

1.9.10 Practices in Denoting Measurement Accuracies: The practices in specifying measurement and instrument accuracy are not uniform and, if not adequately specified or understood, may lead to erroneous interpretation. Different authors may use the terms “accuracy” “error,” and “uncertainty” to denote the estimated difference between the true and measured values, or the limits of error as defined in 1.9.1.

The accuracy of the instrument can be expressed as a percentage of the full scale, or of the reading, or of the combination of both. For instruments measuring quantities with several variables, the expression of accuracy can be more involved. For ac wattmeters, in addition to the frequency, the variables include the magnitudes of voltage and current and the phase angle between the two. The accuracy can be expressed as a percentage of the measured combined voltage and current range.

In most engineering applications the measurement and instrument accuracies are expressed as percentages. The calibration laboratories frequently express accuracies in parts per million (ppm). (One ppm equals 0.0001%.)

1.10 Transportation

The modern electronic instrument, provided that it is surrounded by shock absorbing material, is usually sufficiently robust to withstand the rigors of normal transport. Older instruments, however, particularly those with bearing or taut-band supported meter movements, require more care. If possible, the movement should be clamped to prevent uncontrolled vibrations and relieve the pressure on the bearings. Bearing type meters should be packed face down so as to remove the pressure on the lower bearing, which supports the movement when in use. In car or truck transport, the instrumentation package should be firmly tied down to the vehicle frame to prevent uncontrolled motion and consequent severe shock.

1.11 Safety

Care should be taken in any measurement to avoid coming into contact with dangerous and possible lethal voltages, and also to avoid damage to the installation. Small, hand-held, instruments capable of measuring voltages up to 1 kV or higher are becoming quite common, and it is preferable to place these on some convenient surface when such voltages are applied rather than hold them in one's hand. Leads should be kept clean and in good condition, be insulated to withstand the voltages being accessed, and should be replaced immediately if worn or damaged.

When using current transformers, the possibility of an open circuit across the secondary winding MUST be avoided. Likewise, a short circuit on the secondary winding of a voltage transformer CANNOT be tolerated.

1.12 Bibliography

[1] ANSI C2, American National Standard National Electrical Safety Code.²

[2] ANSI C39 series:

C39.1-1981, American National Standard Requirements for Electric Analog Indicating Instruments.

C39.2-1964 (R1969), American National Standard Direct-Acting Electrical Recording Instruments (Switchboard and Portable Types).

C39.4-1966 (R1972) American National Standard Specifications for Automatic Null-Balancing Electrical Measuring Instruments.

ANSI C39.6-1983, American National Standard for Electrical Instrumentation-Digital Measuring Instruments.

ANSI C39.7-1975, American National Standard Requirements for Electronic Analog Voltmeters.

[3] ANSI/IEEE Std 268-1982, IEEE Standard for Metric Practice.³

[4] IEEE Std 118-1978, IEEE Standard Test Code for Resistance Measurements.

[5] IEEE Std 119-1974, IEEE Recommended Practice for General Principles of Temperature Measurement as Applied to Electrical Apparatus.

[6] IEEE Std 518-1982, IEEE Guide for the Installation of Electrical Equipment to Minimize Electrical Noise Inputs to Controllers from External Sources.

²ANSI publications are available from the Sales Department, American National Standards Institute, 1430 Broadway, New York, NY 10018.

³ANSI/IEEE publications are available from the Institute of Electrical and Electronics Engineers, Service Center, 445 Hoes Lane, Piscataway, NJ 08855-1331, or from the Sales Department, American National Standards Institute, 1430 Broadway, New York, NY 10018.

- [7] Morrison, R. *Grounding and Shielding Techniques in Instrumentation*. New York: John Wiley & Sons, 1986 (Third Edition).
- [8] Ott, H.W. *Noise Reduction Techniques in Electronic Systems*. New York: John Wiley & Sons, 1976.

2. Chapter 2—Voltage and Current Measurements

2.1 Introduction

2.1.1 Digital Instruments

Modern technology has provided digital instruments that can measure voltages and currents over a wide range, and that are accurate, convenient, and rugged. Such instruments are available as dedicated panel meters, portable hand-held multimeters (measuring voltage and current, both dc and ac, and resistance), and portable bench-top meters. For measurements considered in this guide, the latter two types should normally be used.

The basic component of a digital meter is a dc digital voltmeter (DVM). Several operating principles are available. To measure other quantities, a transducer is used at the input of the meter to convert the measured quantity to dc voltage. For example, an internal shunt is used to measure current, and an ac-dc converter to measure ac quantities. The digital meters, in relation to their analog counterparts, have dynamic range and bandwidth and greater accuracy.

2.1.2 Analog Instruments

Prior to the development of reliable digital instruments, accurate measurements were performed by a variety of analog instruments in which a deflection by a pointer provided the measurement information. Most new meters now are of the digital type. However, analog instruments are still available and can be used in power system measurements.

2.1.3 Range Extenders

Modern instruments have a broad dynamic range for the signals that can be measured. The built-in capability of digital meters provides a voltage range that extends typically from 100 mV to 1000 V, and a current range from 100 mA to 10 A. Nevertheless, in power circuits, higher voltages and currents frequently have to be measured. Range-extending devices, such as voltage dividers, instrument transformers, shunts, transducers, and current comparators, are available. These can extend the measurements to about any value encountered in the operation of power circuits.

2.2 Voltage Measurements

2.2.1 General Considerations

2.2.1.1 Description

Voltage measurements in connection with tests under this guide shall generally be made with portable voltmeters. Modern digital voltmeters having rms-sensing capability for ac are now generally available for this purpose. However, older analog meters are acceptable if they meet the accuracy requirements for the intended use. Switchboard and panel instruments are not usually considered acceptable in the applications considered in this guide as they are generally less accurate than portable voltmeters.

2.2.1.2 Calibration

To ensure acceptable performance and accuracy, the meter should be under a regular and periodic calibration regime and adequate records should be maintained. Alternatively, it is necessary to calibrate the meter before and after each use.

2.2.1.3 Caution in Use of Instruments

Possible measurement errors due to conditions of use and environmental factors, such as position, temperature, humidity, stray fields, vibration, ripple on dc signals, waveform of ac signals, and ac frequency must be considered. The effect of the input impedance of the meter on the measured quantity must also be considered.

2.2.2 Digital Voltmeters

2.2.2.1 Introduction

Digital meters display the measured quantities as discrete numbers rather than a pointer deflection on a scale as in analog meters. Electronic circuits are employed in sensing, processing, and displaying the measured quantity. These instruments are generally available as multipurpose digital multimeters (DMMs) enabling measurement of voltage, current, and resistance. Several operating principles are available, such as dual slope conversion, ramp, staircase-ramp, and integrating. Portable meters are available as hand-held digital multimeters or benchtop meters. The higher accuracy meters are usually of the latter type. Almost any accuracy required in engineering applications is available in digital voltmeters—to 0.001% for dc, and 0.01% for ac measurements. Detailed definitions and test procedures for digital meters are available in ANSI C39.6-1983, American National Standard for Electrical Instrumentation—Digital Measuring Instruments [1].⁴

2.2.2.2 Definitions Used with Digital Instruments

The definitions listed below are for selected terms that are most appropriate for measurements in power circuits. They are applicable for both voltage and current measurements.

2.2.2.2.1 Accuracy, Rated: The limit, expressed as percentage of input plus a number of counts, that errors will not exceed when the instrument is used under specified conditions

2.2.2.2.2 Common-Mode Rejection Ratio (CMRR): The ratio in decibels (dB) of the dc or peak ac (sine-wave) common-mode voltage to the equivalent input voltage indicated as an error by the instrument

2.2.2.2.3 Common-Mode Voltage (CMV): The voltage common to both input measuring terminals and a specified reference point, such as the power-line common, the earth ground, the external power-supply common, or the output circuit common, to which the instrument is not intended to respond but which may produce an error in output indication. Unless otherwise stated, common-mode voltage rating shall be with respect to the power-line common

2.2.2.2.4 Digital Multimeter: An electronic instrument that measures voltage, current, and resistance by conversion of the analog input signal to a digital representation in decimal digits

2.2.2.2.5 Dual Slope Conversion: An analog-to-digital (A–D) conversion process in which (a) the input signal is integrated for an interval of time equal to a fixed number of clock pulses (first slope), followed by (b) integration of a reference signal in the opposite direction until the integrator output returns to its initial level (second slope), at which instant (c) the number of clock pulses in the counter, which was reset at the start of the second slope, is now the digital representation of the analog input signal.

2.2.2.2.6 Effective Range: The portion of the range in which measurements can be made to within rated accuracy

2.2.2.2.7 Four-Terminal Resistance Measurements: A measurement in which two wires are used to deliver current to the unknown resistor and two different wires are used to sense the voltage drop across the resistor

2.2.2.2.8 Guarded Input: An input circuit providing a guard electrode surrounding the measuring circuit for the purpose of reducing common-mode interfering currents or providing electrostatic shielding. The guard may be connected to the appropriate point of the complete measuring circuit

2.2.2.2.9 Input Bias Current: The current that must be supplied to the high input measuring terminal with zero input signal and offset voltage to reduce the output indication to zero.

⁴The numbers in brackets correspond to those of the bibliography at the end of this chapter.

2.2.2.2.10 Input Impedance: The shunt resistance and reactance as measured at the input terminals

2.2.2.2.11 Linearity: The ability of an instrument to follow the input signal in a proportional manner over the entire input range. Linearity shall be expressed as the maximum deviation in counts (the number displayed by the least significant digit) from a straight line connecting the ends of the range

2.2.2.2.12 Long-Term Stability: The limit, expressed as a percent of input plus a number of counts that errors will not exceed during a 90-day or other longer specified period. This does not preclude zeroing or similar adjustments that are a part of normal operating procedures and that are made from the front panel without use of external standards or equipment. The error is determined by checking change in output indication after warm-up under the same test conditions within the rated operating limits. The time period includes both operating and nonoperating time

2.2.2.2.13 Peak-Responding: An instrument in which the displayed value is equal to the peak value of the input signal for all repetitive input waveforms having harmonic components within its frequency range.

2.2.2.2.14 Range: A continuous band of input signal values that can be measured. For example: 0 to 100, 20 to 80, -20 to 60. In bipolar instruments, range includes negative as well as positive values

2.2.2.2.15 Ratio Measurement: The measurement of a signal input relative to an external reference input. The output indication is the properly scaled ratio of the signal input magnitude to a reference input magnitude

2.2.2.2.16 Resolution (as Applied to Digital Instruments): The ratio of the smallest incremental change in input signal value, throughout its range, that can be discerned and displayed by an instrument to the highest value of the range

2.2.2.2.17 RMS Responding: A measurement in which the displayed value is equal to the rms of the input signal, for all input waveforms having components within the specified frequency range and crest factor limit

2.2.2.2.18 Short-Term Stability: The limit, expressed as a percent of input plus a number of counts, that errors will not exceed during a 24-hour period of continuous operation under reference conditions following warm-up. No zeroing or adjustments of any kind are permitted

2.2.2.2.19 Two-Terminal Resistance Measurement: A measurement in which the same current flows through the unknown resistance and the test leads. Note that by the use of this technique, the lead resistance is measured along with the unknown.

2.2.2.3 DC Voltage Measurements

The following factors may affect the accuracy of dc voltage measurements made with a digital voltmeter.

2.2.2.3.1 Input Resistance

The error depends upon the resistance of the voltage source, e.g., a voltmeter with an input resistance of 1 M Ω will load a 1 k Ω source causing an error of approximately 0.1%

2.2.2.3.2 Input Bias Current

The error depends on source resistance. An error voltage of 1 mV will be produced at the input terminals of a meter with an input bias current of 1 μ A when measuring a voltage with a source resistance of 1 k Ω

2.2.2.3.3 Insufficient CMRR

An error is introduced by the signal that is common to both input terminals. For example, when measuring a 100 mV signal in presence of 10 V CMV using an instrument with CMRR of 80 dB, an error of $\pm 1\%$ may result. See 2.2.2.2.2 and 2.2.2.2.3

2.2.2.3.4 Maximum CMV

The specified CMRR is not valid if the CMV exceeds specified limits

2.2.2.4 AC Voltage

The following factors may affect the accuracy of ac voltage measurements.

2.2.2.4.1 Operating Principle

Most modern digital meters employ true rms sensing elements which respond to the rms value of any waveform with frequency components within the bandwidth and crest factor limitations of the meter. If other operating principles are employed, significant errors may be observed when measuring nonsinusoidal quantities. For the measurements under this guide, true rms sensing meters should be used

2.2.2.4.2 Input Impedance

The error depends on the impedance of the voltage source (see 2.2.2.3.1) and its ability to drive capacitive loads

2.2.2.4.3 Crest Factor

Depending on the waveform, the meter may have to be adjusted to a higher range to accommodate crest factors that exceed the full-scale crest-factor specification, e.g., a meter with a full-scale crest factor of 5 will not accurately measure a 1 V rms signal with a crest factor of 7, on its 1 V range. Switching to the 10 V range will reduce resolution and possibly accuracy, but will allow measurement of a 1 V signal with crest factors up to 50

2.2.2.4.4 Insufficient CMRR and Maximum CMV

The considerations are similar to dc voltage measurements. See 2.2.2.3.3 and 2.2.2.3.4

2.2.2.5 Accuracy and Resolution

The uncertainty of measurements made with a DMM is normally specified as a percentage of the reading plus a number of counts (which refers to the least significant digit displayed on each range). A $5^{1/2}$ digit DMM with a specified uncertainty of $\pm (0.01\% \text{ of reading} + 10 \text{ counts})$ might read 0.60013 V on the 1 V range. The uncertainty of this reading is given by $\pm (0.0001 \times 0.60013 + 0.00010) = \pm 0.00016 \text{ V}$. If the same measurement were made on the 10 V range the reading might be 0.6001 (the full scale display is only $5^{1/2}$ digits). The uncertainty of this measurement is given by $\pm (0.0001 \times 0.6001 + 0.0010) = \pm 0.00106 \text{ V}$. Most DMMs have an auto range mode that provides maximum resolution and accuracy.

2.2.3 Analog Voltmeters

While most of the new meters are of the digital type, analog meters might be still available to make measurements in power circuits. These meters are constructed using either jewel bearings or taut bands to support the movement of the meter. Taut band types are generally superior because of increased input impedance and greater resistance to mechanical shock. The accuracy of analog voltmeters is in the 0.1–3.0% range, electrodynamic voltmeters intended for laboratory use being the most accurate.

2.2.3.1 Permanent-Magnet, Moving-Coil Voltmeters

This type of instrument is most widely used for dc measurements. As this movement has a low impedance, it requires a series resistance to measure voltages in a circuit. This resistance can be self-contained in the meter or supplied as an accessory to the meter. An external resistor, known as a multiplier, will extend the normal designated voltage range of a voltmeter to a higher voltage.

2.2.3.2 Electrodynamic Voltmeters

This type of instrument is still significantly used in power circuit applications. The deflection of this meter is a result of the reaction between the magnetic field of one or more movable coils and a field produced by one or more fixed coils. The coils are generally connected in series with each other and a series resistance to measure either dc or ac voltages.

See 1.6.5.2 for the details of the operating principle.

2.2.3.3 Soft Iron Vane Voltmeters

This type utilizes the reaction between temporarily magnetized pieces of soft iron and the magnetic field of a fixed coil. When current flows in the coil, both vanes become magnetized with identical polarities and repel each other. The repulsion force provides the torque to drive the pointer and, as pointer deflection is proportional to the product of two magnetic fluxes, the meter is a true rms indicating instrument. These meters are used for power-frequency ac voltages and generally have a nonuniform scale.

Although dc voltage measurements may be made by taking the average of direct and reversed readings, the instrument will have a larger error on direct current.

2.2.3.4 Thermocouple Voltmeters

A simple analog voltmeter of this type has a heater wire in series with a resistance. A thermocouple is attached to the heater wire. The thermocouple provides an emf to drive a low-impedance permanent magnet moving-coil meter. Thermocouple-type rms sensing elements may be used in digital voltmeters. See 1.6.5.3.

2.2.3.5 Electrostatic Voltmeters

The electrostatic voltmeters are still occasionally used in power circuit applications, particularly at moderately high voltages up to 100 kV. The advantages are high-input impedance, high-voltage withstand capability, and true rms sensing capability. Because of low sensitivity they are not generally designed for operation below several hundred volts. The torque is proportional to the square of the applied voltage.

See 1.6.5.1 for the detailed operating principles.

2.2.3.6 Electronic Voltmeters

This term is generally associated with older types of electronic instruments utilizing vacuum tube technology. Because of generally lower accuracy, one should exercise special caution when using such instruments.

2.2.4 High-Voltage Measurements

2.2.4.1 High-Voltage DC Measurements

High dc voltages may be measured with a voltmeter that is preceded by a resistive voltage divider as shown in Fig 2-1. The voltage ratio of the divider is

$$V_2/V_1 = R_2/(R_1 + R_2)$$

Special high-voltage electrostatic meters are used to measure high dc voltages directly. Direct-current dividers are available with accuracies in the 0.01–0.1% range. Electrostatic voltmeters for field use have typically 1.0% accuracy.

2.2.4.2 Precautions in High-Voltage DC Measurements

The resistive divider must have adequate voltage and power ratings. At voltages where corona and leakage currents may present problems, dividers specially designed for the measurement purpose have to be used. The resistance value of R_2 should be sufficiently small to make the errors due to the input resistance of the meter negligible (see 2.2.2.3.1); alternatively, a correction for the loading error must be applied. If R_2 is 1000 Ω or smaller, the input impedance of modern DVMs will not usually present a problem.

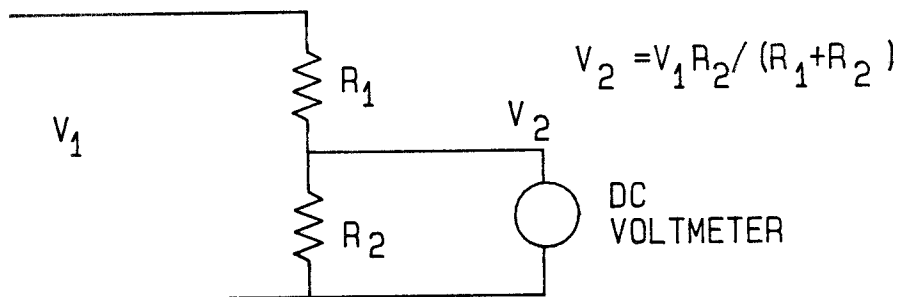

Figure 2-1—Measurement of High Direct Voltages

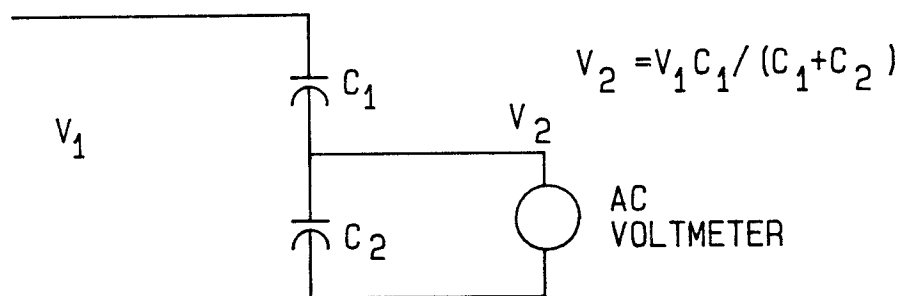

Figure 2-2—Measurement of High Alternating Voltages with a Capacitive Divider

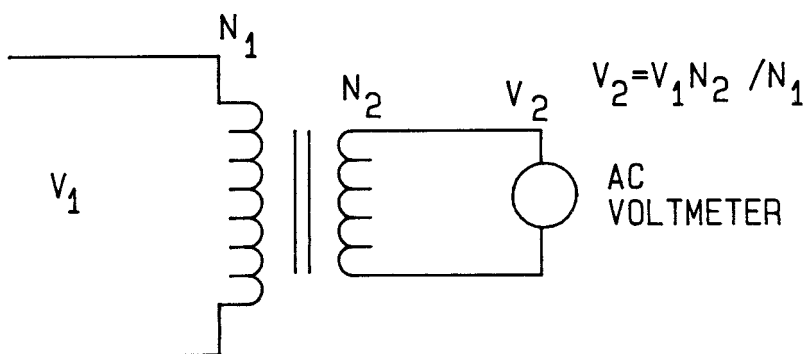

Figure 2-3—Measurement of High Alternating Voltages with a High Transformer

2.2.4.3 High-Voltage AC Measurements

High ac voltages may be measured with a voltmeter that is preceded by a capacitive divider or a voltage (potential) transformer as in Figs 2-2 and 2-3. For the capacitive divider the voltage ratio is

$$V_1/V_2 = C_2/(C_1 + C_2)$$

The voltage transformers are discussed in 2.4. High-voltage electrostatic meters are used directly to measure high ac voltages. Alternating-current dividers with gas-insulated high-voltage capacitors can yield accuracies in the 0.01–0.1% range, those with liquid-solid insulation in the 0.1–1.0% range.

2.2.4.4 Precautions in High-Voltage AC Measurements

The capacitors must have adequate voltage ratings and the capacitance values must be sufficiently large to minimize the effect of stray capacitances. The capacitance of C_2 must be large to reduce the loading errors due to the input capacitance of the voltmeter and of the connecting leads. Special shielded capacitors with gas as the dielectric are available for high-voltage measurements. In these, the stray capacitances are not present and, hence, a more accurate value for C_1 can be realized.

2.2.5 Calibration

2.2.5.1 Calibration of Voltmeters

A portable voltmeter is calibrated either against a standard voltmeter or a standard calibrator as shown in Figs 2-4 and 2-5. The standard instruments should have higher accuracy, should themselves be under a calibration regime, and should have calibration records. In the standard voltmeter method, the two meters are connected to a stable source with adjustable output. The calibrator is a special voltage source having output that is well known. The output voltage and frequency are adjustable.

2.2.5.2 Calibration of Dividers

The resistive and capacitive dividers are calibrated for the measurements under this guide by measuring the values of components, R_1 , R_2 , C_1 , and C_2 with an accurate impedance bridge.

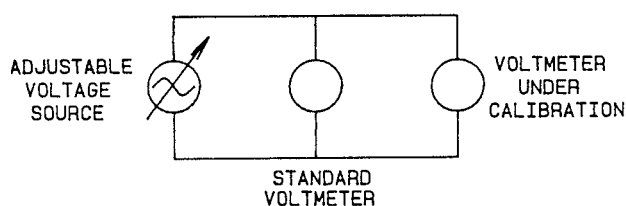

Figure 2-4—Voltmeter Calibration with a Standard Meter

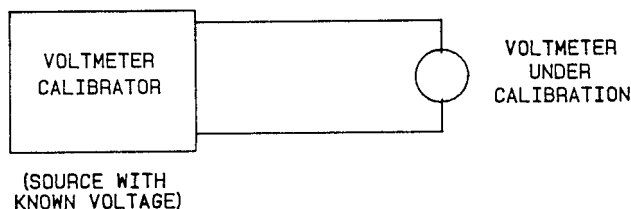

Figure 2-5—Voltmeter Calibration with a Calibrator

Another calibration approach involves the calibration of the divider against a standard divider. This approach may yield a higher accuracy but will, in general, require more costly instruments and more calibration time.

2.3 Current Measurements

2.3.1 General Considerations

Current measurements in connection with tests under this guide shall generally be made with portable ammeters. Modern digital ammeters with high-accuracy capabilities are available for such measurements. Older analog meters are acceptable if they meet the accuracy requirements for the intended use. For ac measurements, instruments that sense the rms value are preferable.

The considerations outlined for voltmeters in paragraphs 2.2.1.2 and 2.2.1.3 also apply to ammeters.

2.3.2 Digital Ammeters

Modern digital meters that would be typically used for measurements in power circuits are available as DMM combining the functions of a voltmeter, ammeter, and resistance meter. Hence, the definitions as presented in paragraphs 2.2.2.2.1 to 2.2.2.2.19 apply also to digital ammeters. Current measurements are essentially performed by digital voltmeters using internal shunts through which the currents are passed. The voltage drop across the shunt is measured. Several factors discussed below may affect the accuracy of dc and ac measurements.

2.3.2.1 DC Measurements, Factor Affecting Measurement Accuracy

2.3.2.1.1 Maximum Nondestructive Current

The maximum current must be maintained below this limit to avoid permanent accuracy degradation or failure of the instrument.

2.3.2.1.2 Internal Resistance (Voltage Burden)

The internal resistance of an ammeter may introduce measurement errors that depend on the internal resistance of the current source being measured; e. g., a DMM with a $0.1\ \Omega$ internal resistance will require $0.5\ \text{V}$ and dissipate $2.5\ \text{W}$ when measuring a $5\ \text{A}$ current. If the effective output resistance of the current source is $1000\ \Omega$, the output current of the source will decrease by $0.5\ \text{mA}$ or by 0.01% .

2.3.2.1.3 Insufficient CMRR

A voltage common to both terminals may introduce an error in the instrument reading (see 2.2.2.3.3).

2.3.2.2 AC Measurements, Factors Affecting Measurement Accuracy

2.3.2.2.1 Accuracy Considerations Similar to DC Measurements

Considerations relating to maximum nondestructive current, internal impedance, and common-mode rejection ratio apply also to ac measurements. See 2.3.2.1.1, 2.3.2.1.2, and 2.3.2.1.3.

2.3.2.2.1 Crest Factor

The crest factor consideration is similar to that of ac voltmeters, see 2.2.2.4.3.

2.3.3 Analog Ammeters

Analog ammeters are similar to their voltmeter counterparts and the considerations discussed in 2.2.3 to 2.2.2.3.4 also apply here.

2.3.3.1 DC Ammeters

A moving-coil millivoltmeter in conjunction with an internal or external shunt is used for dc measurements. The deflection is proportional to the voltage across the shunt and, hence, to the current through it. A low-range millivoltmeter is used so that the energy loss in the shunt is not large. The instrument is calibrated in amperes.

2.3.3.2 AC Ammeters

These can be of the electrodynamic, soft iron vane, or thermocouple type. The characteristics are similar to those of the voltmeters of the same type. See 2.2.3.2, 2.2.3.3, and 2.2.3.4.

2.3.3.3 “Clamp-on” Ammeters

This type of instrument consists of a meter proper and a current transformer with a split core that can be clamped on a primary winding in which the current is measured. The “clamp-on” ammeters are useful for making approximate measurements of alternating current in various parts of the test circuit prior to connection to more accurate and fragile meters. Clamp-on meters should not be used where accuracy is important.

2.3.4 Ammeter Shunts

Shunts, either internal or external, are integral parts of all digital ammeters and of analog dc ammeters, regardless of current magnitude. Meters without external shunts or other scaling devices typically measure maximum currents from 1 to 10 A. Above those values, external devices are used with the measuring instruments.

2.3.4.1 DC Shunts

A shunt is constructed to have, as nearly as possible, a constant resistance under all conditions. The resistance metal has a low-temperature coefficient of resistance and the temperature rise is kept low by improving heat dissipation with parallel strip construction. The resistance metal should have a low thermal emf against copper for two reasons: first, if one end of the shunt becomes hotter than the other because of poor contact at one current connection or to a poor connection in the cable or bus structure near that end of the shunt, a thermal emf will be produced in addition to the potential drop across the shunt; second, when current passes through the junction of two dissimilar metals which have a thermal emf with respect to each other, a Peltier effect results, that is, heat is absorbed or produced. Hence, one junction tends to become cool and the other to become hot and the resultant difference in temperature will produce an emf. Accuracies between 0.01% and 0.1% are available.

2.3.4.2 DC Shunts for Large Currents

Large direct currents are measured in the same manner as small currents, i.e., with millivoltmeters connected to shunts—the shunts being correspondingly larger in physical dimensions and lower in resistance. Certain precautions should be observed, however, when using large shunts. Shunts of several thousand amperes in capacity should be designed with long, multiple-leaf copper blocks to ensure that the current distribution will be uniform through the shunt and will be the same after installation as when it was calibrated. Every time a large shunt is connected to a multiple-leaf bus structure, the contact resistance distribution is changed, and if the junction is close to the resistance strips, the current will not be distributed uniformly among them.

In installing large capacity shunts in a bus structure they should preferably be placed in a horizontal bus run with the leaves mounted in a vertical plane, the shunts being so located in the bus structure as not to be immediately adjacent to right-angle turns in the bus. In addition, they should not be mounted in immediate proximity of devices that are

likely to produce heat that would raise the temperature of the shunt unevenly and they should never be mounted vertically as the upper terminal would be heated by rising air currents. This latter practice would result in a thermal-gradient across the shunt. All shunt connection surfaces should be clean and the connections made tight.

2.3.4.3 AC Shunts

Shunts are employed to measure alternating currents. The same built-in shunts are used in digital multimeters for dc and ac measurements. The use of shunts in power circuits is restricted to relatively small currents, typically to several tens of amperes. For higher currents a preferred scaling device is the current transformer. The accuracy of ac measurements may be affected by the self-inductance of the shunt or the mutual inductance between various parts of the measurement circuit. At power frequencies inductive reactance effects may become significant for low-resistance shunts having resistance values of 1 m Ω or smaller. Special construction techniques are available to produce shunts with very low inductances. Such shunts may take the forms of coaxial cylinders or ribbon resistors constructed in a bifilar manner. The shunts built for large direct currents will be inadequate for alternating currents not only because of their inductive reactance but also because of possibly large skin effect that will tend to increase the ac resistance substantially above the dc value. Whenever shunts are used in ac applications, their ac characteristics should be ascertained. Carefully constructed ac shunts have accuracies that are similar to those of the dc shunts.

2.3.5 Measurement of Large Currents Using Other Scaling Devices

For measurement of large direct currents, the ranges of ammeters can be extended by using transducers, Hall-effect devices, or current comparators as alternatives to shunts described in 2.3.4.2. For large alternating currents the preferred method involves current transformers. Mutual inductors (Rogowski coils) can also be used in special circumstances.

2.3.5.1 A Simple Transducer for Measurement of Large Direct Currents

A simple transducer consists of two single-phase transformers, with the direct current to be measured passing through the primary windings in series, while the secondaries are connected through the meter to a source of ac voltage. The secondary windings are connected in series and in opposite phase as shown in Fig 2-6. The cores are driven far into saturation by the direct current, but are unsaturated every half cycle by the alternating-current source. While either core is unsaturated, the secondary current in it is related to the primary current by the turns ratio, so that when direct current flows in the primary, the secondary current is approximately a square-wave at the same frequency as the supply. Rectifying this secondary current generates a direct current which is a measure of the direct current in the primary. This current contains double-frequency pulses due to the secondary current dropping to zero.

2.3.5.2 Improved Transducers

An improved transducer with the secondary windings connected in parallel is shown in Fig 2-7. With the windings in parallel, the secondary current flows through the load continuously, essentially eliminating the double-frequency pulses. Resistors shown in parallel with two of the rectifiers connect the ac excitation voltage source to the winding on the saturated core in such a way that the core flux is reset in preparation for the next half cycle when it must be unsaturated.

Further improvement in accuracy can be obtained by the addition of a bias winding over both cores and a transistor feedback circuit, as shown in Fig 2-8. The bias winding has the same number of turns, N_e , as that of the secondary windings. The error is reduced by driving a correction current through the load and the resistors R_1 , and R_2 . Due to the current gain of the transistor, T_1 , the current through the bias winding is much larger than that through the secondary windings of the basic transducer. Therefore, besides the improvement in accuracy, the current range of the basic transducer is also extended.

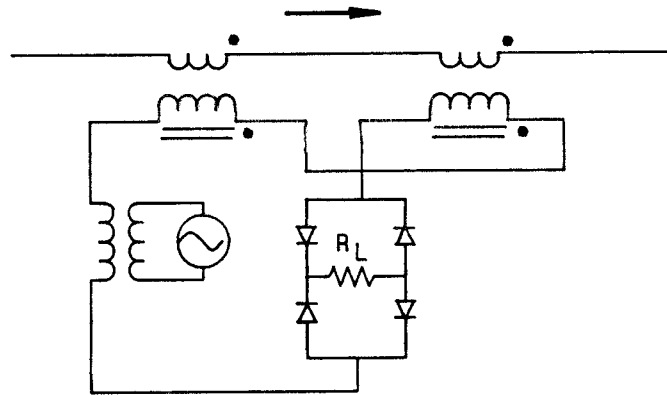

Figure 2-6—Simple Transducer

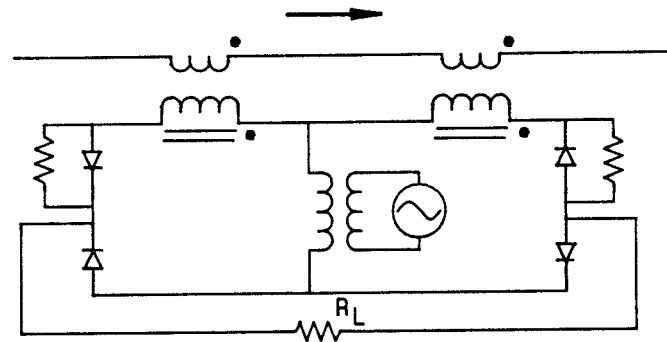

Figure 2-7—Improved Transducer

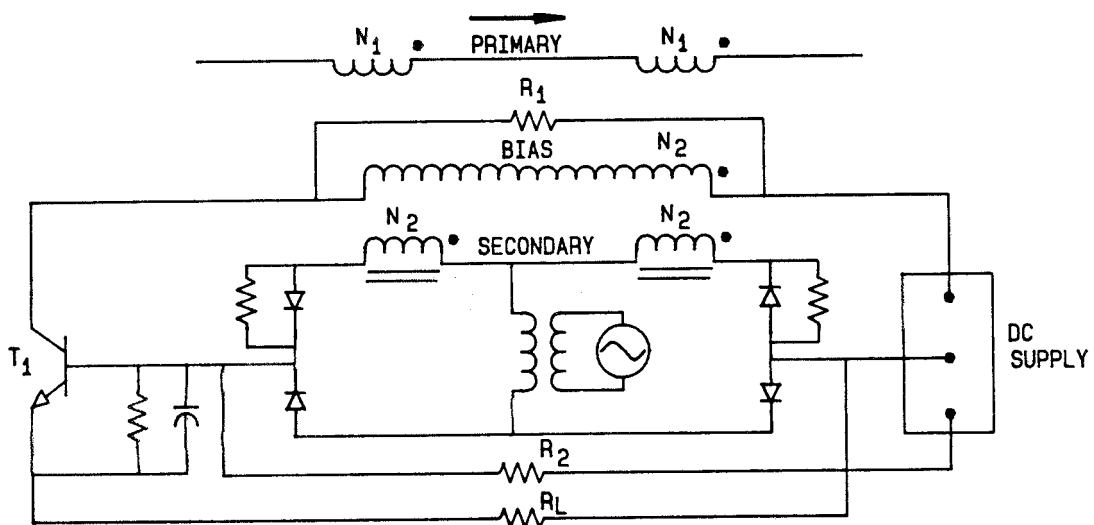

Figure 2-8—Transducer with Bias Winding and Amplifier

Conventional transducers normally have error limits of 0.1–2%, while improved transducers can have error limits, of less than 0.01–0.1%.

2.3.5.3 Hall-Effect Current Transformers

A Hall-effect current transformer consists of a single-phase transformer with an air gap and a Hall element, which is a semiconductor device placed in the air gap. If a constant current is passed through a Hall element located in a transverse magnetic field, a voltage is generated in the Hall element on an axis perpendicular to the current and the magnetic field. This voltage is proportional to the current and the magnetic flux density. Since the magnetic flux density in the air gap is proportional to the primary current, the voltage is also proportional to the primary current. Thus the voltage is a measure of the current in the primary winding. In the Hall-effect current transformer, the voltage of the Hall element is fed back through a transconductance amplifier to the secondary winding so as to compensate the primary ampere-turns. The Hall element is thus used as a null device and the secondary current is related to the primary current by the turns-ratio of the winding. Since the Hall element has a frequency bandwidth from zero to several megahertz, Hall-effect current transformers can also be used for the measurement of large ac currents. They normally have limits of 0.5–2%.

2.3.5.4 Self-Balancing DC Comparators

A dc comparator is an ampere-turn balance indicator based on the detection of the zero flux condition in a magnetic core. It consists of two toroidal cores of high-permeability magnetic material, a magnetic shield in the form of a hollow toroid which surrounds the cores, and ratio windings over the shield which carry the currents to be compared. The two cores are driven into saturation twice per cycle by a magnetic modulator. Direct current in the ratio windings causes an even harmonic voltage to be produced that is detected by a peak detector. The magnetic shield shields the cores from external fields and winding leakage fluxes, so that the need for a special environment and careful ratio-winding distribution is practically eliminated. It also suppresses the currents that would be induced by the modulator in the ratio-windings. The comparator is made self-balancing by the addition of a slave power supply, controlled by the peak detector, which supplies the current required to keep the net ampere-turns in the ratio-windings equal to zero. Thus the self-balancing comparator performs like a current transformer that operates down to zero frequency, that is, direct current. Direct-current comparators can be built for laboratory applications having error limits of less than 0.001%.

2.3.5.5 Precautions in Measuring Large Direct Currents

While the dc comparator is essentially unaffected by its operating environment, the accuracy of transducers and Hall-effect current transformers, depending on their design, are usually affected by ambient magnetic fields. Special precautions should be taken when using these devices for measuring large bus currents. The physical location of the bus relative to remainder of the device will influence the error, and, therefore, calibrations should preferably be made in situ. The possible presence of stray magnetic fields should always be considered. Such fields may be produced by currents in neighboring conductors or buses, by certain electric machines, and by other apparatus.

2.3.5.6 Current Transformers for Alternating Currents

Self-contained ac ammeters have a maximum range typically between 1 and 10 A. Current transformers are most commonly used to extend the range to several thousand amperes and, for larger transformers, to 75 000 A. With respect to accuracy capabilities, current transformers range from 0.3% for uncorrected metering transformers to 0.001%, or even better, for laboratory units. Further details of instrument transformers are presented in 2.4.

2.3.5.7 Mutual Inductors (Rogowski Coils)

A uniformly wound toroidal inductor can be used to measure large alternating or pulsed currents that are passed through the opening of the toroid. The voltage in the winding is induced by the current that is measured and, hence, it is a derivative of the current. The output is therefore integrated before being read-out. In design and construction of Rogowski coils, attempts are made to approach ideal characteristics so that the coil will only sense the current through its opening and will reject any external currents. Accuracies of about 0.1% can be achieved in laboratory units and 1.0% in the devices used in the field.

2.3.6 Calibration

2.3.6.1 Calibration of Ammeters

A portable ammeter is calibrated either against a standard ammeter or a standard calibrator. The standard instruments should have higher accuracy, should themselves be under a calibration regime, and should have calibration records. In the standard ammeter method the two meters are connected in series to a stable current source with adjustable output. The calibrator is a special current source having an output that is well known. The output current and frequency are adjustable.

2.3.6.2 Calibration of Range Extending Devices

The devices—shunts, transducers, current transformers, and current comparators—are usually calibrated or verified against higher accuracy devices that fall in the similar category of instruments. Such calibrations are diverse, they frequently involve sophisticated standard instruments, and may require highly skilled and specialized personnel. No generalizations can be made; however, a few examples are presented. Direct-current shunts may be calibrated with a Kelvin bridge or with a current comparator combined with a low-current shunt in the secondary winding; alternating-current shunts may be calibrated with an accurate current transformer having a known ac resistor in the secondary winding. Transducers and Hall-effect transformers may be calibrated with a dc current comparator. Self-contained “build-up” calibration techniques are available for the highest accuracy ratio devices, such as special current transformers or current comparators.

2.4 Instrument Transformers

2.4.1 Function of Instrument Transformers

Instrument transformers often are used for operating relays and other control apparatus as well as in conjunction with electrical measuring instruments. The only application that is considered here is that of measurements. In this connection they are used for the purpose of (a) reducing the voltages and currents to values that can be measured conveniently—usually to values that can be measured with instruments having ranges not exceeding 150 V and 5 A, respectively, and (b) insulating the measuring instruments from the high potential that may exist on the circuit under test.

Instrument transformer practice is described in detail in the ANSI/IEEE C57.13-1978 (R1987), IEEE Standard Requirements for Instrument Transformers [2].

2.4.2 Distinctive Features—Voltage (Potential) Transformers

Voltage (potential) transformers are quite similar in general design and in appearance to small capacity power transformers of small capacity. Both windings are of relatively small wire because only very small power capacity is required. The primary is connected directly to the line (often through protecting fuses) and the secondary to the instrument.

2.4.2 Distinctive Features—Current Transformers

Current transformers consist of two windings that are well insulated from one another and from the iron core upon which they are placed. The primary consists of a few turns, or even only one turn in the form of a section of bus bar, and is connected in series with the circuit under test. The secondary current, corresponding to a given primary current, is only slightly affected by the number of instruments connected in the secondary circuit, provided their total burden does not exceed the rating of the transformer.

Current transformers are designed to operate at comparatively low flux densities and, therefore, low magnetizing current when operating at or below their rated burdens.

Portable current transformers are commonly available in two types:

- 1) With permanent primary and secondary windings; the transformer may have several primary windings rated for different currents, or the primary winding may have a provision for series-parallel interconnection;
- 2) With a permanent secondary winding and a window in the core for the placement of a primary winding as required. This type is known as a window-type of transformer.

2.4.4 Transformer Theory, Equivalent Circuit Representation

The design and construction of the two types of instrument transformers are different, but the same transformer theory applies to both. Transformers can be represented by an equivalent circuit consisting of an ideal transformer and a T-network as shown in Fig 2-9. The nominal ratio is usually the actual turns ratio; Z_a and Z_b are the leakage impedances, including the winding resistance, of the windings N_a and N_b , respectively; and Z_m is the magnetizing impedance. For operation as a step-down voltage transformer, V_a is the input (primary) voltage and V_b the output (secondary) voltage, since $N_b < N_a$. For operation as a step-down current transformer, I_b is the primary current and $-I_a$ the secondary current. The equivalent circuit representation is convenient for the analysis of the nature of transformer errors.

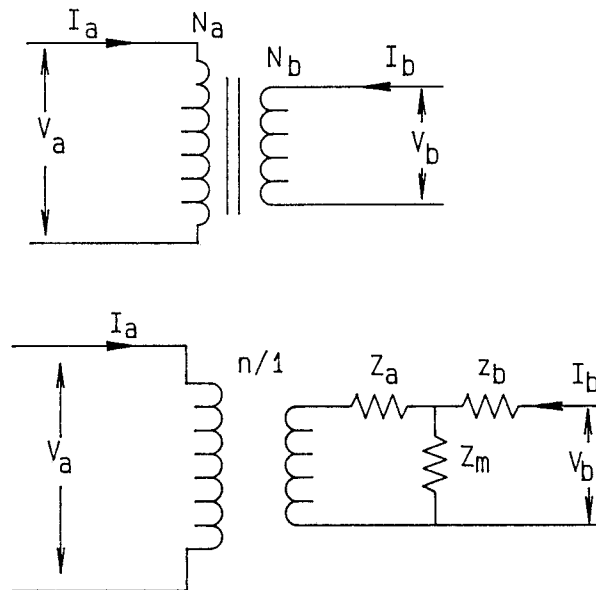

Figure 2-9—Transformer and Its Equivalent Circuit

2.4.5 Definitions Related to Instrument Transformer Ratio, Phase Angle, and Correction

The terms in 2.4.5.1–2.4.5.6 are consistent with the formally defined terms in ANSI/IEEE C57.13-1978, IEEE Standard Requirements for Instrument Transformers [2]. Other terms given in 2.4.5.7 are used in technical literature. See the phasor diagrams of Fig 2-10 for the relationship of terms defined here.

2.4.5.1 Marked Ratio: The ratio of the rated primary value to the rated secondary value as stated on the nameplate.

2.4.5.2 Ratio Correction: The difference between the ratio correction factor and unity. It is usually expressed in percent, but can also be expressed as a fraction (in per unit).

2.4.5.3 Ratio Correction Factor (RCF): The ratio of the true ratio to the marked ratio. The primary current or voltage is equal to the secondary current or voltage multiplied by the market ratio times the ratio correction factor.

2.4.5.4 Phase Angle: The phase displacement between the primary and secondary values. It is positive when the phasor of the secondary value leads that of the primary value.

2.4.5.5 True Ratio: The ratio of the rms primary value to the rms secondary value under specified conditions.

2.4.5.6 Turns Ratio: The ratio of the primary winding turns to the secondary winding turns.

2.4.5.7 Other Terms: Besides the formally defined terms in ANSI/IEEE C57.13-1978, IEEE Standard Requirements for Instrument Transformers [2], technical literature uses the following additional terms:

Nominal ratio. This term is usually used (also in ANSI/IEEE C57.13-1978 [2]) as a simple number and is sometimes substituted for the marked ratio. For example, the marked ratio of a voltage transformer might be 4800 V:120 V, the nominal ratio is 40 or 40/1.

In-phase correction. The in-phase component between the phasors representing the nominal secondary value (primary value divided by the nominal ratio) and the secondary value. This correction is normalized by dividing it by the secondary value and it is nearly the same as the ratio correction in 2.4.5.2.

Quadrature correction. The quadrature component between the phasors representing the nominal secondary value and the secondary value. For small phase angles the quadrature correction is numerically nearly equal to the phase angle in radians.

The above two corrections are normalized with respect to the secondary value. Technical literature also describes corrections that are normalized with respect to the primary value. Section discusses the mathematical relationships between the various terms used from 2.4.5.1-2.4.5.7. Figure 2-10 complements this discussion.

2.4.6 Mathematical Relationship Between the Phasors of Quantities in Instrument Transformers

The mathematical ratio of the primary and secondary quantity (voltage or current) phasors of an instrument transformer is a complex number that in polar coordinates has a magnitude deviation from the marked ratio and a phase angle. Such a relationship is given by

$$Q_1/Q_2 = N(1 + a)e^{-jb}$$

where Q_1 and Q_2 are the primary and secondary quantities, respectively; N is the marked ratio; $(1 + a)$ is the ratio correction factor; a is the ratio correction; and b is the phase angle in radians. The phasor diagram of Fig 2-10(a) illustrates the preceding quantities.

For small b , a Cartesian form of the relationship is readily obtained:

$$Q_1/Q_2 = N(1 + a_1 - jb_1)$$

where a_1 and b_2 are usually denoted as in-phase and quadrature corrections, respectively. For small angles, a and a_1 are nearly equal, as are b and b_1 . The diagram of Fig 2-10(b) illustrates the Cartesian coordinate representation.

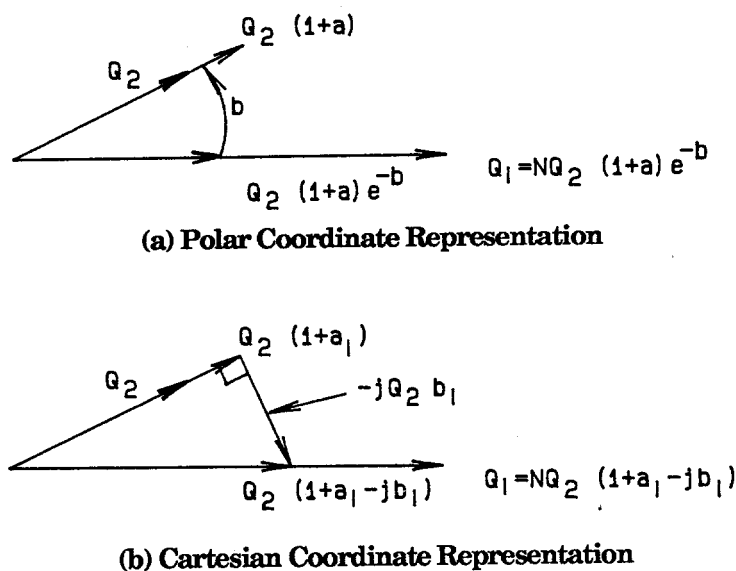

- Q_1 = Primary Quantity
- Q_2 = Secondary Quantity
- N = Marked Ratio
- $(1 + a)$ = Ratio Correction Factor
- a = Ratio Correction
- b = Phase Angle
- a_1 = In-phase Correction
- b_1 = Quadrature Correction

Figure 2-10—Phasor Diagrams Illustrating Terms Used with Instrument Transformer Ratio and Deviations

2.4.7 Relationship of Transformer Corrections to the Parameters of Equivalent Circuit

The impedances and the ratio of the transformer in the equivalent circuit of Fig 2-9 can be readily related to the complex number expressions in . The equivalent circuit provides an insight into the nature of instrument transformer errors under various operating conditions.

In voltage transformer operation without a burden, V_a is the primary voltage ($N_a > N_b$), and the complex quantity becomes

$$V_a/V_b = (N_a/N_b)(1 + Z_a/Z_m)$$

Similarly, in current transformer operation without a burden (zero impedance), I_b is the primary current and the complex quantity is as before

$$-I_b/I_a = (N_a/N_b)(1 + Z_a/Z_m)$$

In both cases

$$a_1 - jb_1 = Z_a/Z_m$$

yielding the information that is necessary to obtain the true ratio, the ratio correction factor, and the phase angle.

2.4.8 Polarity

When instrument transformers are used with instruments or relays that operate only according to the magnitude of the current or voltage, the phase position is of no consequence. When instrument transformers are also used with wattmeters and certain other instruments, the operation depends on the interactions of two currents. Hence, for the correct operation of such devices the currents must be in correct relative phase, and it becomes necessary to know the relative directions of the currents in primary and secondary windings of the instrument transformers. This is indicated by marking one primary and one secondary terminal with a distinctive polarity marker so that when the current direction is toward the transformer in the marked primary lead, it is away from the transformer in the marked secondary lead. The connection for instrument transformers is illustrated for the power measurement of a 3-phase, 4-wire load in Fig 2-11.

2.4.9 Rating

Instrument transformers are rated according to the nominal ratio of primary to secondary current or voltage. They are also rated for the burden that the transformer will carry without causing errors greater than a specified amount. In the case of current transformers, the rated primary current and the maximum voltage of the circuit to which a transformer may be safely connected are also indicated. Similarly, voltage transformers are rated for a maximum safe primary voltage.

2.4.10 Advantages and Disadvantages in Using Instrument Transformers

The particular advantages gained by using instrument transformers are

- a) Safety, since they permit the measuring instruments to be electrically insulated from the equipment under test.
- b) Flexibility, since they permit the instruments to be located at any convenient place, not necessarily adjacent to the equipment under test.
- c) Workability, since they make the wiring of the instruments much easier because of the small current and low voltage values.
- d) Adaptability, since one set of instruments may be used with several transformers of suitable ratios for all measurements. The disadvantage in using instrument transformers is that, in accurate measurements, corrections must be determined and applied to the instrument indications to take care of the variation of the true ratio from the marked ratio and also the variation of the phase angle from the ideal (zero).

2.4.11 Range and Accuracy

Current and voltage transformers are available in standard makes for practically any desired range up to about 75 000 A and about 500 000 V, respectively. Higher ranges may be obtained, but such transformers would be special.

In general, for particularly accurate measurements the secondary current of a current transformer should be between 10 and 100% of its rated current. Voltage transformers are not, in general, designed to operate at voltages far from their nominal ratings since their constants do change materially with variations over the order of 10% from the rated voltage.

In certain cases, it is entirely possible that an error of the order of 1% may be introduced into the measurements by failure to make the necessary corrections for deviation from the marked ratio and for phase-angle displacement. The magnitude of such corrections depends upon (1) the burden (number and kind of instruments connected to the transformer), (2) the secondary current (in the case of current transformers), and (3) in the case of power measurement, the power factor of the device being measured. Especially when measuring power at low power factor, correction for phase-angle displacement must be made because of the possible excessive error. See 3.1, for discussion of phase-angle correction.

2.4.12 Nature of Deviations from Nominal Ratio in Voltage Transformers

The deviations without a burden are discussed in within the context of the equivalent circuit of Fig 2-9. The deviation is introduced by the voltage divider that is formed by Z_a , and Z_m ; Z_b does not affect the ratio without a burden. Since the voltage transformer is usually operated near its rated voltage, the magnetizing impedance remains nearly constant and so do the ratio correction and the phase angle. This may not be so if it is desired to operate the voltage transformer at a drastically reduced voltage.

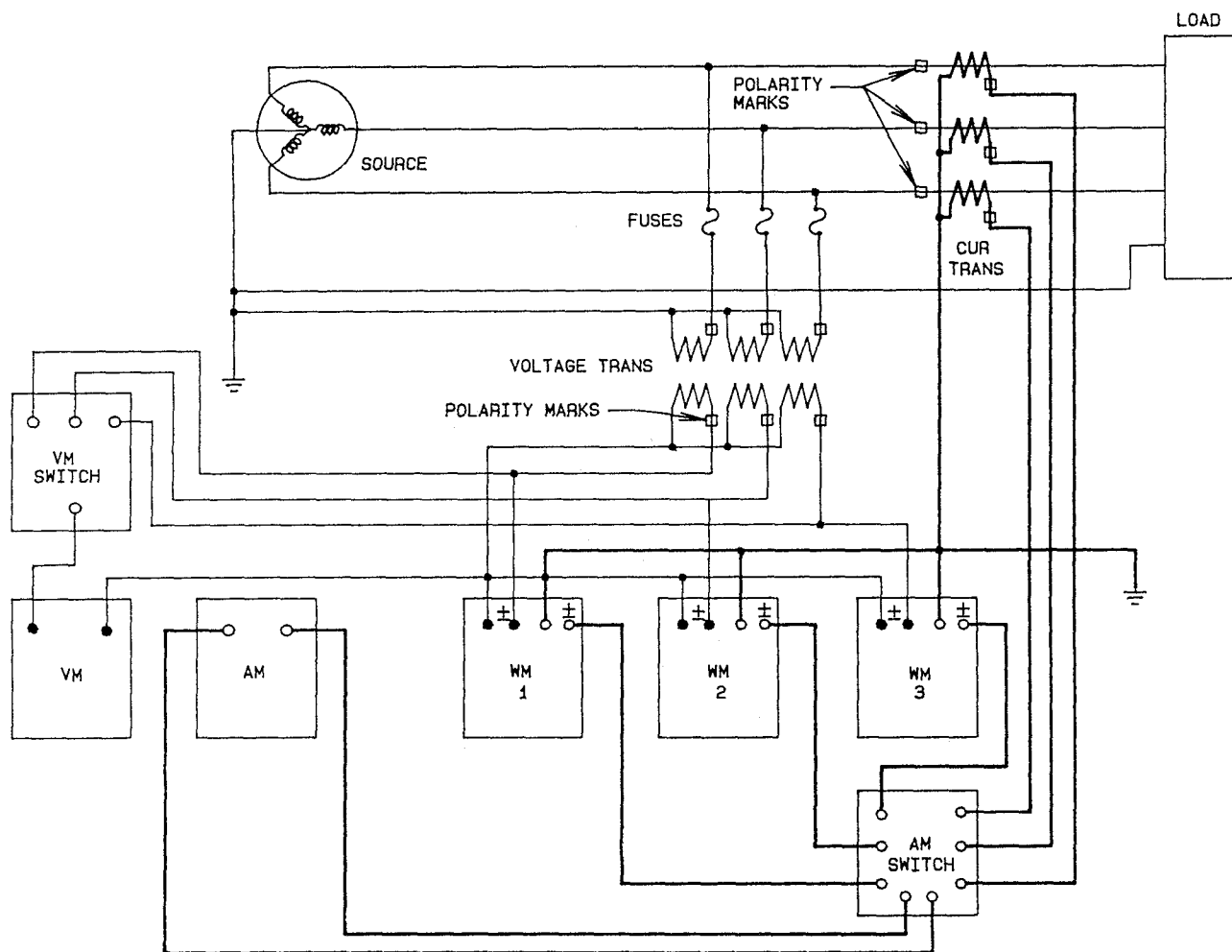

Figure 2-11—Tranformer Connections for Measurement of a 3-Phase, 4-Wire (Circuit)

Additional deviation is introduced by the burden impedance that is connected to the output winding. The effective output impedance of the transformer and the burden impedance form a voltage divider that further modifies the ratio and phase angle of the transformer. The output impedance value of the transformer is primarily the sum of the two leakage impedance values and, therefore, is constant. The changes in ratio and phase angle due to burden impedances can be calculated by employing linear circuit considerations. The output impedance, Z_o , can be determined by observing the shift in the ratio and phase angle due to a known burden impedance. The additional in-phase and quadrature corrections, a_2 and b_2 , due to the burden impedance, Z_B , are given by

$$a_2 - jb_2 = Z_o/Z_B$$

Z_O is determined, for example, by observing a_2 and b_2 for a known burden impedance of Z_B . By knowing Z_O , a_2 and b_2 can be determined for any other known Z_B .

2.4.13 Nature of Deviations from Nominal Ratio in Current Transformers

The deviations without a burden (zero impedance) are discussed in within the context of the equivalent circuit of Fig 2-9. The deviation is introduced by the current divider that is formed by Z_a and Z_m ; Z_b does not affect the ratio and the phase angle. The current transformer is usually operated over a wide dynamic range, e.g., the output current from 0.5–5.0 A. Over such a range the magnetizing current is not proportional to the output current, i.e., Z_m , is not constant. Hence, the corrections depend on the output current and should be measured over a number of points in the operating range.

Additional corrections are introduced by the burden impedance. The burden effects are also nonlinear and therefore difficult, if not impossible, to calculate. As a result, a set of correction curves should be established over the range of operating currents and burdens.

A further complication is introduced by the fact that the magnetizing current is affected by inadvertent residual magnetization of the core. This can be caused by switching operations and by unintentional rectification effects in the circuit. For the highest accuracy the cores should be demagnetized before the calibration and before critical measurements. Demagnetization is achieved by bringing the core to saturation by supplying a variable voltage to the secondary winding and then by reducing the voltage to zero. A variable auto-transformer is useful for this purpose.

2.4.14 Grounding of Instrument Transformers

In using instrument transformers, care should be taken to ground the frame or case and one side of the secondary circuit of each transformer in order to remove the danger to the observer and to the instruments should the insulation between primary and secondary break down. In grounding the secondary circuits of transformers connected to a polyphase circuit, care should be taken not to ground at more than one point if the secondaries are interconnected; otherwise, a short circuit between phases will result.

2.4.15 Precautions in the Use of Instrument Transformers

In using current transformers, care should be taken never to open the secondary circuit while current is in the primary winding because of the dangerously high voltage which may be developed and the excessive temperature rise which may ultimately take place due to high losses in the transformer. Also, opening the secondary circuit may leave the core of the transformer magnetized, resulting in a change in the ratio and phase-angle characteristics. When it is necessary to open the secondary circuit, in order to change instruments for example, the secondary winding should be short-circuited, preferably at the transformer terminals.

If the secondary circuit is accidentally opened, possible magnetization of the core should be removed. In the case of voltage transformers care should be taken to avoid short-circuiting the secondary. In other words, the circuit should be treated as any electric circuit of ordinary voltage. This circuit may, of course, be opened whenever desired.

The secondary circuits of instrument transformers should not be overloaded by placing too large burdens in them (that is, too many instruments, meters, relays, etc.) because of the resulting increase in the ratio errors and phase angle.

In portable current transformers of the window type, the primary conductor is passed through a hole in the core. Each time the conductor passes through the hole it counts as one turn, and the position of the conductor or conductors in the hole, or the size and distribution of the loop between turns, does not materially affect the ratio and phase angle. However, a small error of the order of 0.1% in ratio or 1 milliradian in phase angle may be the result and, where this is significant, the position of the conductors in the test should correspond with that used in the calibration.

2.4.16 Special Techniques for Accuracy Improvement

In an ideal transformer having a core of infinite permeability, zero core loss, and no leakage flux, the secondary current would be exactly in opposition to the primary current, the voltages would be exactly proportional to the number of turns, and the true ratio of transformation would equal the ratio of turns. As discussed before, none of these conditions exists in simple transformers.

In some classes of engineering measurements, corrections may be neglected entirely, but in accurate measurements of voltage, current, power, and energy, the true ratio should always be known. In addition, the phase angle should be known in power and energy measurement.

For instrument transformers that are designed for metering applications, the deviations from the marked values must remain within 0.3% and 3 milliradian. By calibrating the transformers and applying the corrections, the uncertainties can be reduced to about 0.1–0.01% (1–0.1 milliradian). The limitations are imposed by the calibration accuracy and the stability of the transformer under changing environmental conditions.

Technology is now available for constructing transformers that for practical purposes have negligible corrections and uncertainties. The techniques for achieving highly accurate transformers include

- 1) the use of high-permeability, low-loss core materials;
- 2) three-winding voltage transformers and current comparators;
- 3) two-stage transformers;
- 4) zero-flux transformers;
- 5) amplifier-aided transformers.

By optimizing the designs of transformers to increase accuracy without altering the basic two-winding configuration, improvements by at least a factor of ten over what is available in conventional metering transformers can be achieved. An important contributor to improved current transformers is the availability of high-permeability, tape-wound toroidal cores. They retain very high permeabilities at the lowest required flux densities.

2.4.17 Current Comparators and Three-Winding Voltage Transformers

The adverse effects of the excitation current is avoided in a transformer having three windings. In a voltage transformer, the core is excited from one of the windings (excitation winding). The open-circuit voltage ratio in the remaining two windings (ratio windings) approaches the turns ratio within 0.001% or better. By employing magnetic shielding between the ratio and excitation windings, uncertainties can be reduced to a level below 0.0001% or one part per million (ppm). The three-winding current transformer version is known as the current comparator. Two currents are passed in the ratio windings to produce zero magnetization in the core. A null detector is connected to the third, now called the detection winding. The null condition corresponds to ampere-turn balance. Any small residual errors are due to linear effects and are thus identical in both modes of operation. Such devices are employed in impedance bridges and various instrument calibrators. They cannot be directly substituted for conventional two-winding transformers, but with additional sources and the detector they might be employed as ratio standards in calibration of conventional transformers.

2.4.18 Two-Stage Transformers

A two-stage transformer has three windings and two magnetic cores. It is similar to a three-winding transformer, except that the detection/excitation winding has the same number of turns as one of the ratio windings—usually the one with more turns. These two windings are connected in parallel with separate leads from both windings brought to the common terminals in order to minimize the impedance that would be common to both windings. The extra core is placed between the ratio windings and the third winding. Sometimes the additional core is constructed to surround the first core with its winding and thus serve as a magnetic shield. Such a composite transformer has characteristics of a nearly ideal transformer if operated without an external burden. In the voltage transformer mode of operation, the

primary voltage is applied to the parallel combination of the windings; in the current transformer mode the primary current is supplied to the ratio winding that is not in parallel with other windings.

The composite two-stage transformer really consists of two transformers—a regular two-winding instrument transformer and a three-winding transformer that compensates for the excitation effects of the regular transformer. In terms of the equivalent circuit of Fig 2-9, the two-stage technique transfers the leakage impedance Z_a to the other side of the magnetizing impedance, Z_m , in series with Z_b . Deviations from the turns ratio in no-burden operation are of the order of 1 ppm or even smaller. The ratio is unaffected by the signal level. Subject to insulation and core saturation limits, the transformer is reciprocal and can be used either as a current or a voltage transformer. The advantages of two-stage technique disappear if the external burden becomes significant. A schematic diagram of a two-stage transformer is shown in Fig 2-12.

2.4.19 Zero-Flux Transformers

Zero-flux transformer technique is another method of compensation for the effects of the transformer excitation. A regular and a compensating current transformer are employed. The primary windings are connected in series. The secondary windings of both transformers are connected in parallel to a compensating burden impedance that is adjustable. The regular transformer has its own regular burden in series with its secondary winding. The secondary current of the compensating transformer is nominally twice that of the regular current transformer. The compensating transformer and the compensating impedance act as an effective negative impedance in series with the secondary winding of the regular transformer. This negative impedance is adjusted to cancel the impedances of the secondary leakage impedance and the burden impedance. Thus there is little or no excitation required in the core of the regular transformer to produce the current in its secondary winding. The compensation impedance must be readjusted after changes in the external burden impedance. Uncertainties can be reduced to the 0.001% level.

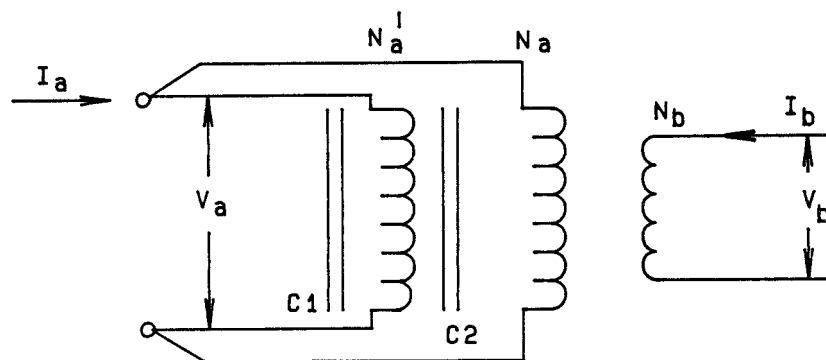

Windings N_a and N_b are placed on both cores, C1 and C2; windings N_a , having the same number of turns as N_a , is placed only on core C1.

Figure 2-12—Two-Stage Transformer

2.4.20 Amplifier-Aided Transformers

Numerous techniques have been described for the reduction of the errors of instrument transformers, particularly current transformers, by means of feedback amplifier techniques. Typically an amplifier senses a signal in a transformer that causes a ratio deviation and then supplies an output voltage or current to reduce the deviation. In terms of the equivalent circuit model of Fig 2-9, the amplifier circuit can be designed to increase the effective magnetizing impedance, Z_m , decrease the leakage impedances, and decrease the effective external burden. Since deviations in well-designed transformers are already small, the amplifiers need not have very high gains for further reduction of errors. Because of possible dynamic instabilities, increased chance for electromagnetic interference, and decreased reliability, great care should be exercised in design and use of transformers with active compensation. Such techniques have been used in standard transformers for calibration purpose and in transformers that are included in very accurate measuring instruments.

2.4.21 Calibration, General Considerations

The usual practice is to calibrate separately the instrument transformers and the instruments that are connected to them. Where high voltages and high currents are involved this may be the only practical alternative. Also, the instrument transformers will usually have better stability and will require less frequent calibration than the instruments that are connected to them. Where the total instrumentation system is very complex, system-based accuracy verification might be desirable in addition to calibration of individual instruments and, whenever possible, should be explored.

Well-designed instrument transformers are exceptionally stable devices. Furthermore, the failures tend to be catastrophic—open and short circuit—and thus are readily recognized. Subtle defects associated with significant ratio changes are rare and are usually caused by poor contacts, mechanical abuse of the transformer, and partial short circuits in current transformers. After thorough initial calibrations to establish the performance of the device, complete calibrations need to be performed only infrequently, e.g., every five years. Means for spot-checking the instrument transformer, such as another transformer, is highly desirable.

For metering purposes the transformers are calibrated to 0.1% accuracy (See ANSI/IEEE C57.13-1978, IEEE Standard Requirements for Instrument Transformers [2]). Other applications, e.g., low-power-factor power measurements, require much greater accuracies. Technology is available to produce stable transformers with low ratio and phase angle deviations and to calibrate them to any accuracy that may be required in practical measurement situations.

2.4.22 Calibration, Voltage Transformers

In a typical industrial practice, a voltage transformer would be calibrated against a standard transformer or a capacitive divider having the same nominal ratio as the transformer under calibration. In the case of a standard transformer method, the primary windings of the two transformers are connected in parallel to the power source. The small difference between the secondary voltages is measured with a voltage comparator circuit that provides the readings of transformer ratio and phase angle corrections.

The calibration against a capacitive divider is conceptually similar; there are, however, some practical differences. A provision should be made for determining the ratio of the divider, since capacitors may not have the same long-term stability as standard transformers. Whenever possible, stable gas-di-electric capacitors, free from losses, should be used in both arms of the divider. Special techniques have been developed to adapt capacitive dividers for calibration of high-voltage ratios.

The accuracy of the standard transformer method depends on the accuracy of this standard. Uncertainties between 0.01% and 0.03% are typical, but further uncertainty reduction is still possible. Capacitive dividers or capacitance bridges are capable of 0.001% and even lower uncertainties. Two calibration circuits involving a capacitive divider in the first and a high-voltage capacitance bridge in the second are shown in Fig 2-13.

2.4.23 Calibration, Current Transformers

Current transformers are calibrated against standard transformers or similar devices. The primary windings of the two transformers are connected in series. The small difference between two nominally equal secondary currents can be measured with a variety of circuits that provide the readings of ratio and phase angle deviations of the transformer under test relative to the standard transformer. The accuracy is governed almost entirely by that of the standard transformer; 0.01% uncertainty is typical for ordinary standard transformers.

A two-stage current transformer is particularly attractive as the standard because it has negligible deviations from the nominal ratio (see 2.4.6). The calibration convenience is further increased by using a compensated current comparator as the standard. A compensated current comparator is obtained by placing another winding on that core of the two-stage transformer that is linked by all the windings. The extra winding is used for sensing the flux in the core to ensure ampere-turn balance with respect to all current-carrying windings. The compensated current comparator technique

removes whatever residual error the two-stage transformer may have due to a non-zero external burden and, more importantly, due to very high effective impedance in the secondary winding. The compensated current comparator allows excitation of the entire calibrating circuit from the secondary winding of the compensated current comparator. The power source in the secondary winding introduces very large effective negative impedance in this winding that would upset the accuracy of a two-stage transformer. The compensated current comparator technique removes this problem. The calibration circuit using a compensated current comparator is shown in Fig 2-14.

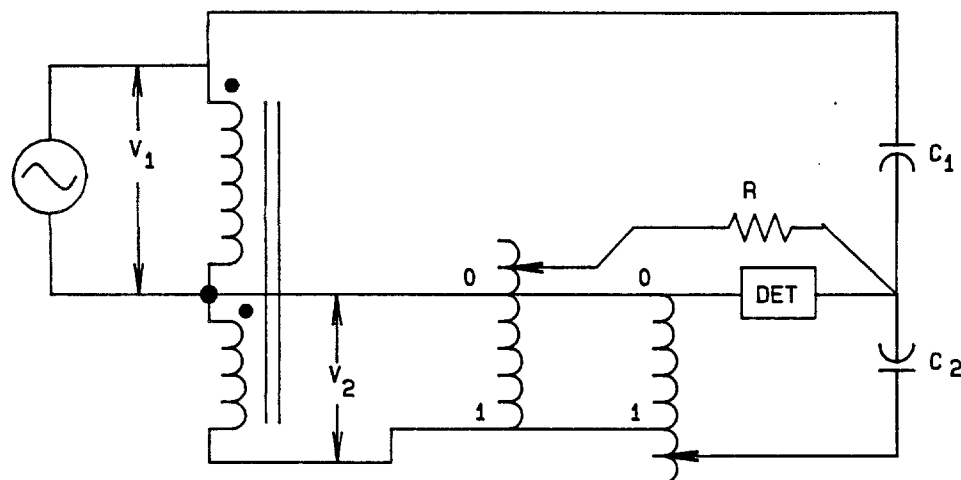

(a) Capacitive Divider Method

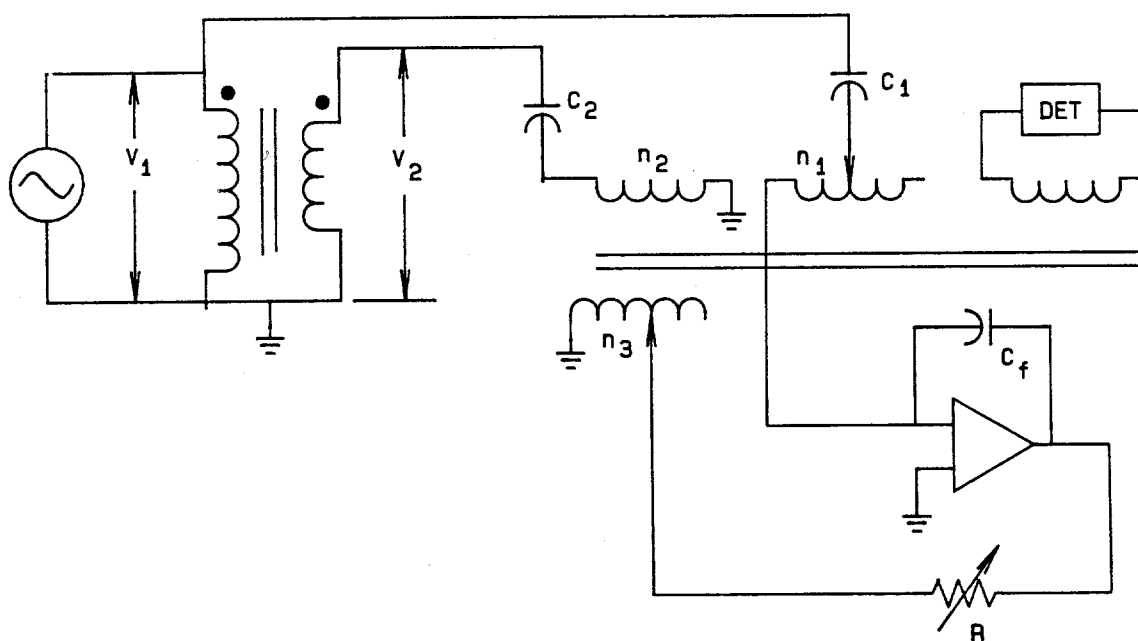

(b) Capacitance Bridge Method

Figure 2-13—Calibration of Voltage Transformer

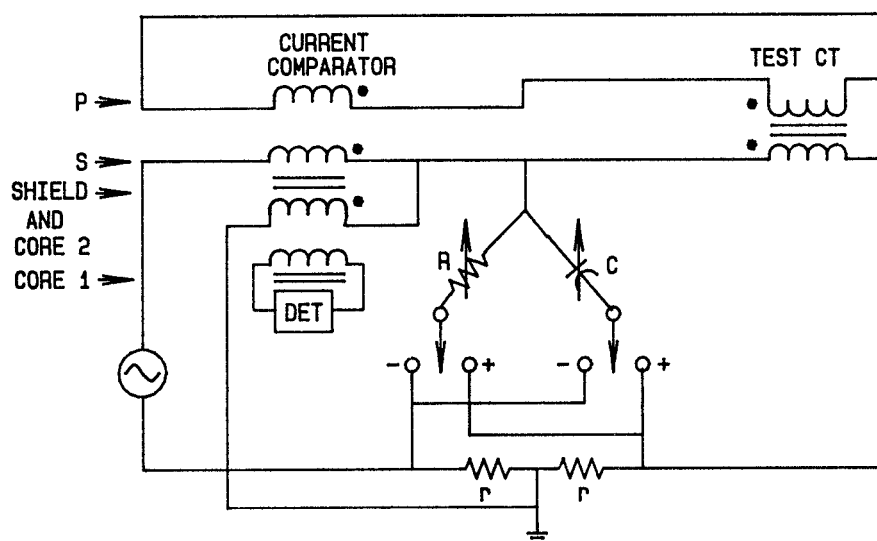

Figure 2-14—Calibration of Current Transformer Using Compensated Current Comparator

2.5 Bibliography

- [1] ANSI C39.6-1983, American National Standard for Electrical Instrumentation—Digital Measuring Instruments.⁵
- [2] ANSI/IEEE C57.13-1978 (R1986), IEEE Standard Requirements for Instrument Transformers. (Contains an extensive bibliography on instrument transformers and their calibrations⁶)
- [3] Harris, F. K. *Electrical Measurements*. New York: John Wiley & Sons, Inc., 1952. (Includes descriptions of analog meters, shunts, instrument transformers.)
- [4] Kitchin, C. and Counts, L. *RMS to DC Conversion Application Guide*. Analog Devices, Inc., 1983.
- [5] Clothier, W.K., and Medina, L. The Absolute Calibration of Voltage Transformers, *Proc. of IEEE*, Vol. 104A, June 1957, pp. 204–214.
- [6] Kusters, N.L. and Petersons, O.A. Transformer-Ratio-Arm Bridge for High-Voltage Capacitance Measurements. *IEEE Transactions on Communications and Electronics*, No. 69, Nov. 1963, pp. 606–611.
- [7] Miljanic, P.N., Kusters, N.L., and Moore, W.J.M. The Application of Current Comparators to the Calibration of Current Transformers at Ratios up to 36,000/5 Amperes. *IEEE Transactions on Instrumentation and Measurement*, Vol. IM-17, Sept. 1968, pp. 196–203.
- [8] Moore, W.J.M. and Miljanic, P.N. *The Current Comparator*. London, United Kingdom: Peter Peregrinus Ltd., 1988.

⁵ANSI publications are available from the Sales Department, American National Standards Institute, 1430 Broadway, New York, NY 10018.

⁶ANSI/IEEE publications are available from the Institute of Electrical and Electronics Engineers, Service Center, 445 Hoes Lane, Piscataway, NJ 08855-1331, or from the Sales Department, American National Standards Institute, 1430 Broadway, New York, NY 10018.

3. Chapter 3—Power, Energy, and Power Factor

3.1 Power Measurement

3.1.1 AC Power

Power is defined as the rate at which energy is being transferred or consumed. Energy is the time integral of power over a period of time.

In electrical circuits, the power is the time average of the product of the instantaneous values of voltage and current. Under steady dc conditions the power P (in watts) is equal to the product of the voltage V (in volts) and the current I (in amperes). Symbolically, $P = VI$. With sinusoidal alternating currents, the power (in watts) is equal to the product of the rms (root mean square) value of the voltage (in volts), the rms value of the current (in amperes), and the power factor (which, under sinusoidal waveform conditions, is the cosine of the phase angle θ between the current and voltage). Thus, for undistorted alternating current

$$P = VI \cos \theta$$

In balanced and symmetrical 3-phase systems

$$P = \sqrt{3}VI \cos \theta$$

where V = line-to-line voltage

Power is sometimes called active power to distinguish it from reactive power. Reactive power is present in circuits where energy storage devices such as inductors and capacitors are involved, but it is orthogonal to active power and does no work. Currents associated with reactive power, however, can cause active power losses and overheating in connected equipment.

The reactive power for undistorted waveforms is given by the expression

$$Q = VI \sin \theta \text{ for single-phase loads}$$

and

$$Q = \sqrt{3}VI \sin \theta \text{ for balanced and symmetrical 3-phase loads.}$$

The apparent power is defined as the simple product of the rms values of current and voltage, regardless of distortion.

$$S = VI \text{ for single-phase}$$

and

$S = \sqrt{3}VI$ for balanced and symmetrical 3-phase loads. In networks with non-sinusoidal waveforms, a simple phase angle, θ , does not exist. While the expression of the apparent power remains the same as above, the expression for active power, P , becomes the sum of the active powers at each frequency present. The reactive power in this case is

$$Q = (S^2 - P^2)^{1/2}$$

For a given voltage V and current I , S can be regarded as the maximum active power that can be transmitted. This will take place when the power factor is unity, i.e., $\cos \theta = 1$.

Power can be measured in a variety of ways. Instruments that measure power are usually called wattmeters if their output is in visual form, or watt transducers if further processing is required.

3.1.2 Methods of Measurement

3.1.2.1 Electrodynamic Wattmeters

Both current and potential elements are present.

The current or series element consists of two fixed coils wound with heavy wire or strip, connected in series with each other and with the main circuit. The potential element is a moving coil with a large number of turns of fine wire which is connected in series with a noninductive resistor across the main circuit. The coil is located between the two fixed coils and may be supported by a shaft with spiral restraining springs between two jewel bearings or by a taut band stretched between two fixed mounts. The output indication may be either a fixed pointer or a light beam/mirror system. This light beam/mirror system suspended by a taut band is noted for the low burden or tare that it imposes on the circuit in which it is connected.

The electrodynamic wattmeter may be used for both dc and low (power) frequency measurements. Power for its operation is taken from the circuit in which it is being used. The best accuracy attainable is of the order of 0.1%.

3.1.2.2 Time-Division Multiplier Wattmeters

The time-division multiplier (TDM) wattmeters use electronic switching circuits with two input signals proportional to the voltage and current. The switching action converts the first input signal in a train of pulses. Either the pulse width, the pulse frequency, or the pulse pause duration is fixed or modulated as a function of the first input signal. The second input quantity modulates the pulse amplitude in such a way that the pulse area represents the multiplication product of voltage times current. A low-pass filter supplied by the pulses will yield an output signal proportional with the active power. Power for their operation is obtained from an auxiliary source.

TDM wattmeters can have accuracies approaching 0.1% and have a large frequency bandwidth.

3.1.2.3 Thermal Wattmeters

The thermal wattmeter is based on using a single junction or multijunction thermal converter either alone or in a differential configuration to realize “quarter square” multiplication. A quantity proportional to the product of the two input variables (voltage and current) is obtained when the square (or heating value) of the difference between the two inputs is subtracted from the square of their sum. To avoid difficulties arising from nonlinearities and duplication of their conversion characteristics and their response time, the thermal converters are used in a null detecting mode. Direct-current feedback is added to the difference input to make its heating value equal to that of the sum input, thus achieving null and faster response. The magnitude of the direct current provides a measure of the product or power. This can be used to provide a digital display or to drive a time-integrating device to measure energy.

Thermal wattmeters can have accuracies approaching 0.01% or better and a medium frequency bandwidth. Power for their operation is obtained from an auxiliary source.

3.1.2.4 Digital Wattmeters

Digital wattmeters take samples of the voltage and current during the period of the fundamental frequency, converting the amplitude of each sample into a digital number by analog-to-digital converters. Corresponding amplitudes of voltage and current are then processed digitally to obtain the time average product or power.

Digital wattmeters, depending on their clock rate, can have a very wide frequency bandwidth. Their accuracy, however, is limited to the resolution of the analog-to-digital converters. Accuracies of 0.1% or so are currently available.

Digital wattmeters should not be confused with other meters that have digital displays only.

3.1.2.5 Electronic Analog Wattmeters

Electronic analog wattmeters perform their multiplication in analog form. They are relatively inexpensive but also not very accurate. Accuracies of 1% or so are typical.

3.1.3 Environmental Considerations

Before measurements of power are actually made, an assessment of the possible influence of various environmental factors, such as temperature, magnetic fields, and electric fields, should be made. The operating temperature limits and warm-up time of the instrument are usually specified by the manufacturer. Some form of shielding against the ambient magnetic and electric fields may also be provided. To check whether this shielding is adequate, the following test can be made:

- 1) Short circuit the voltage input at the point where the voltage is to be measured by disconnecting the higher potential lead from the circuit and connecting it to the terminal where the other voltage lead is connected. If a voltage transformer intervenes, this reconnection can be made at the transformer secondary terminals.
- 2) Open circuit the current input by shifting the lead at the higher potential terminal of the instrument to the lower potential terminal. The current circuit is thus maintained while the current input is bypassed. If a current transformer intervenes, this reconnection may be made at the transformer primary terminals.
- 3) Apply the test voltage to the circuit being measured and observe the output indication of the instrument. This should be lower than the resolution required in the measurements and is one of the factors to be taken into account when estimating the overall uncertainty.

3.1.4 Connections

It is not possible to use a wattmeter to measure power in a circuit without including the burden of either the voltage input circuit or the current input circuit in the measured quantity. This is not much of a problem with electronic instruments that use a separate source of power and that usually have high-impedance voltage inputs and low-impedance current inputs. However, care should be taken in applying the electromechanical-type instruments that derive their operating power from the circuit being measured. Calculations should be made to see if the power drawn by the relevant input circuit of the meter is significant, where the voltage and current input connections should be made relative to each other, and whether corrections should be made. Moreover, the voltage input lead impedance must be kept sufficiently small relative to the voltage input impedance.

3.1.4.1 Connection Diagrams

In single-phase circuits, the measurement of power is implemented in accordance with Fig 3-1. It is essential to make sure that the polarized terminal (marked \pm or $*$) of the current coil is connected toward the source of energy. The voltage polarized terminal is connected with the current polarized terminal.

When instrument transformers are also used with wattmeters and certain other instruments, the operation depends on the interactions of two currents; hence, for the correct operation of such devices, the currents must be in correct relative phase, and it becomes necessary to know the relative directions of the currents in primary and secondary windings of the instrument transformers. This is indicated by marking one primary and one secondary terminal with a distinctive polarity marker so that when the current direction is toward the transformer in the marked primary lead, it is away from the transformer in the marked secondary lead.

In a system involving n conductors, Blondel's Theorem says that $n - 1$ wattmeters are required. Measurements are made with current inputs taken from all but one of the conductors, the voltages from between the conductors from which the current inputs are taken and the omitted conductor. The sum of the individual meter measurements is equal to the total power.

The connection diagram for a single-phase, 3-wire circuit or a 3-phase, 3-wire circuit is shown in Fig 3-2. Two instruments are used and the total power is the sum of the two readings. If the power factor is less than 0.5, one meter yields a negative reading and the total power is given by the difference between the readings.

In 3-phase systems with 4-wire circuits, three instruments are needed (Figs 3-3 and 3-4). The connections in 3-phase, 3-wire circuits, where voltage and current transformers are used, are presented in Fig 3-5.

3.1.5 Phase-Angle Errors

There are three phase-angle errors to be considered in making accurate power measurement. These are

- 1) the phase-angle error of the wattmeter, usually assigned to the voltage input;
- 2) the phase-angle error of the current transformer, if used; and
- 3) the phase-angle error of the potential transformer, if used.

They are usually designated by the Greek symbols α , β , and γ , respectively. The effect of these phase-angle errors is to make the angle between the voltage and the current in the wattmeter larger or smaller than that between the current and the voltage of the circuit being measured; the error thereby produced depends on the power factor of the main circuit.

The phase-angle errors of the wattmeter, the voltage transformer, and the current transformer should all be determined by calibration. In particular, caution should be exercised in attributing all of the phase-angle error of electromechanical wattmeters to the inductance of the voltage input circuit. Shunt capacitance across the multiplying resistor, mutual inductance between the voltage and current input circuits, and eddy currents in the surrounding metal enclosures also contribute to the phase-angle error in an opposing sense and may, in combination, have the greater effect.

The phase-angle error of a wattmeter is positive if, when measuring under leading power-factor conditions, the indication is larger than nominal. The phase-angle error of a voltage transformer is positive if the actual leads the nominal secondary voltage and, of a current transformer, if the actual secondary current leads the nominal secondary current. Lagging power-factor angles are considered positive and leading, negative. See Fig 3-6.

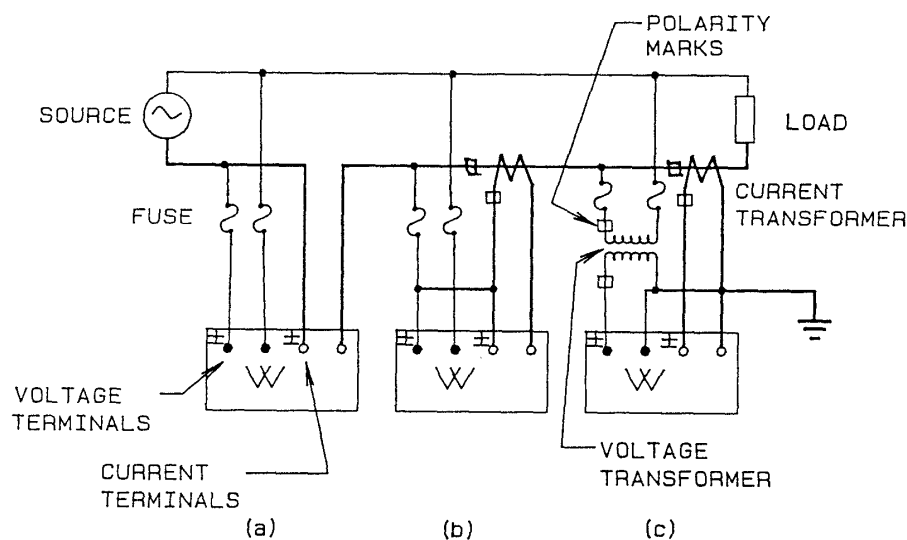

Figure 3-1—Measurements in Single-Phase Circuits:
(a) Without Transformers (b) With Current Transformer (Note: No ground connection.)
(c) With Current and Voltage Transformer

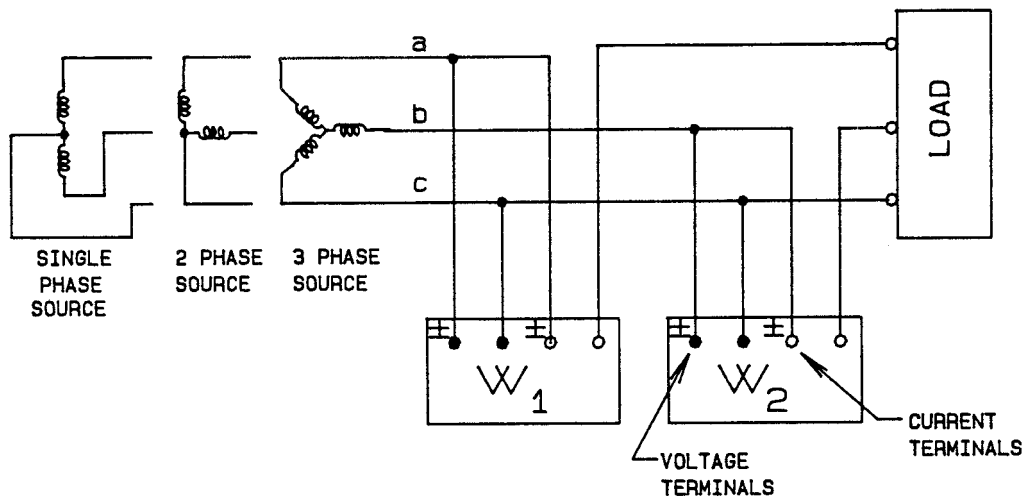

Figure 3-2—Single-Phase, 2-Phase, or 3-Phase, 3-Wire Circuit

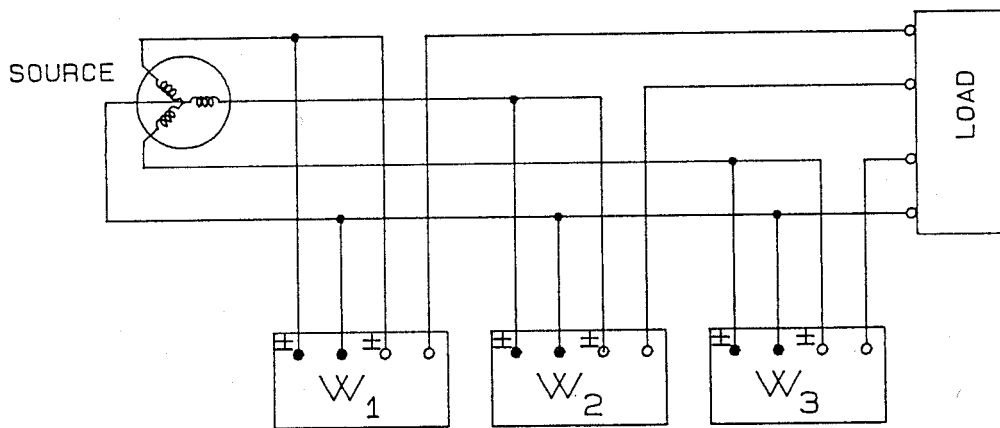

Figure 3-3—Connections in 3-Phase, 4-Wire Circuits, Using Three Instruments

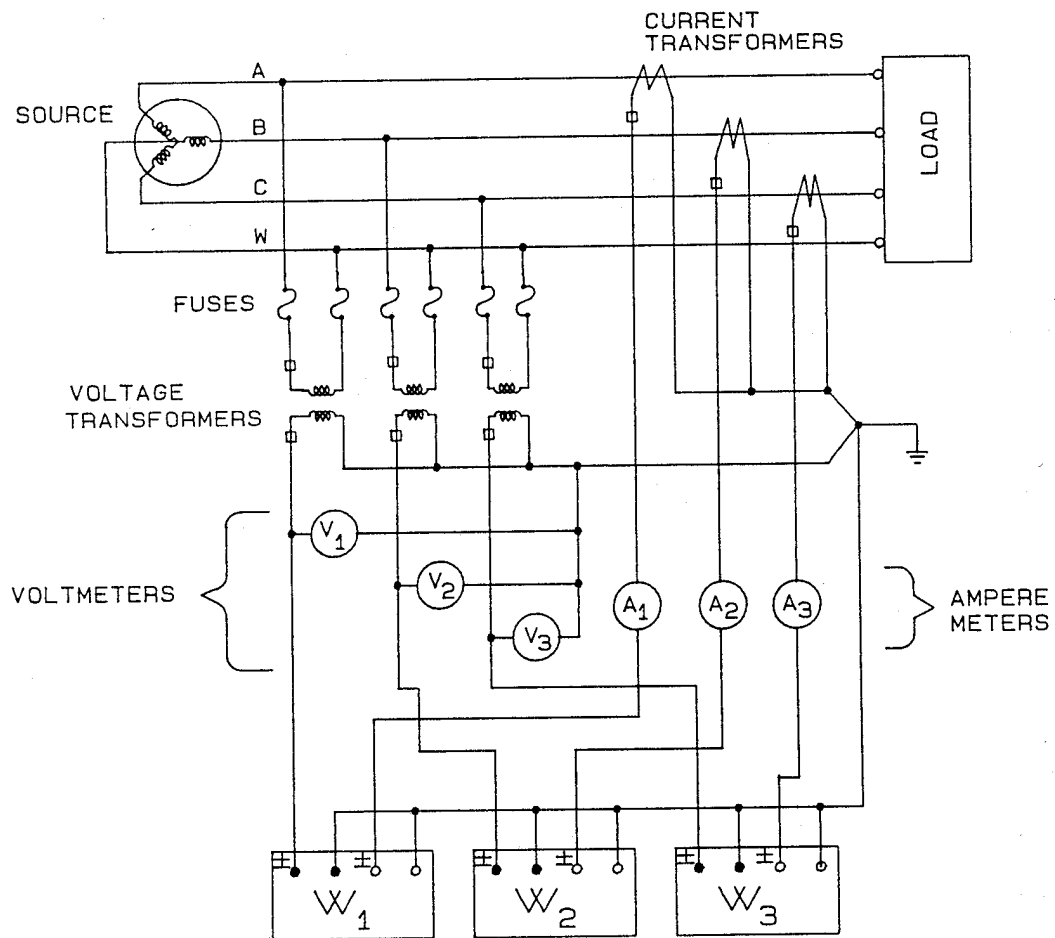

Figure 3-4—Connections with Both Voltage and Current Transformers in 3-Phase, 4-Wire Circuits Using Three Instruments

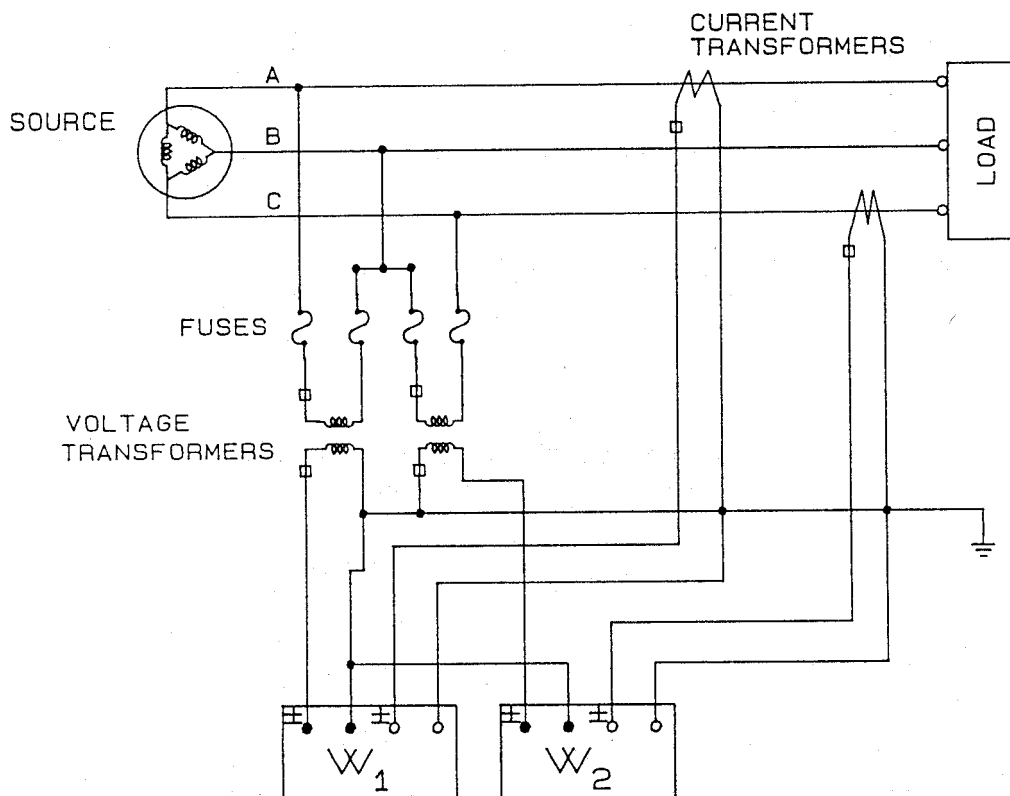

Figure 3-5—Connections with Both Voltage and Current Transformers in 3-Phase, 3-Wire Circuits Using Two Instruments

In order to correct wattmeter readings for phase-angle errors, it is necessary to determine the phase-angle correction factor (PACF). This factor is expressed mathematically as

$$\text{PACF} = \frac{\cos \theta}{\cos \theta_2}$$

where $\cos \theta_2$ = indicated power factor

The true power-factor angle, θ , between the primary current and primary voltage is obtained by algebraically adding the phase-angle error of the wattmeter, the phase-angle error of the current transformer, and the phase-angle error of the voltage transformer to the indicated power factor angle, θ_2 . Then

$$\theta = \theta_2 - \alpha + \beta - \gamma$$

$$pf = \cos \theta = \cos [\theta_2 - \alpha + \beta - \gamma]$$

$$\text{PACF} = \frac{\cos [\theta_2 - \alpha + \beta - \gamma]}{\cos \theta_2}$$

The value obtained for the phase-angle correction factor from this last formula along with the ratio correction factor for the current and voltage transformers, and the wattmeter scale correction, are to be used in determining the true power.

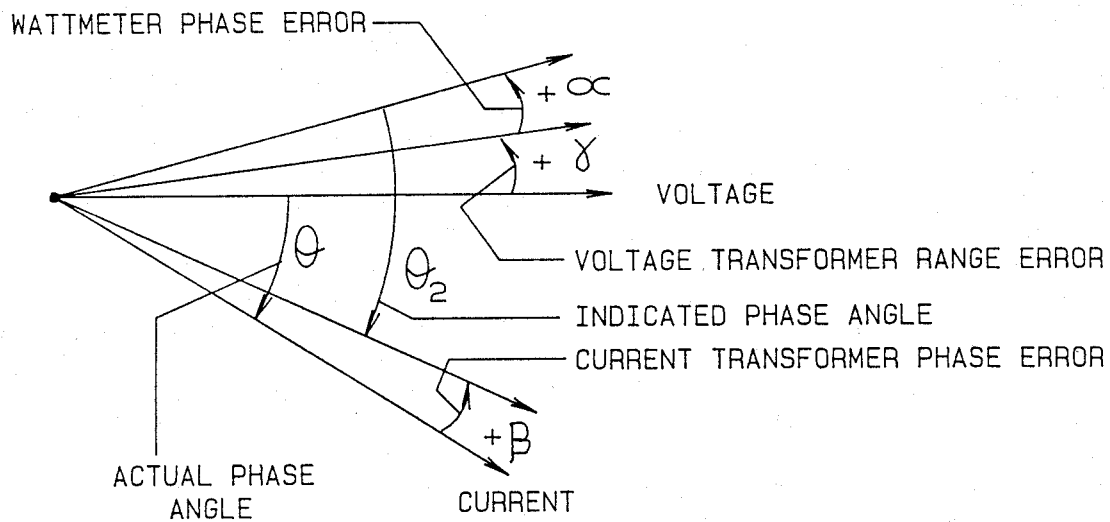

Figure 3-6—Phase Angles Associated with Power Measurements

Example: Wattmeter Reading Corrected for Phase-Angle Errors of Wattmeters and Ratio and Phase-Angle Errors of Instrument Transformers

Data: Lagging Current, $f = 60$ Hz

C.T. Ratio = 39.64:1

V.T. Ratio = 19.94:1

Voltage = $(19.94)(104.4) = 2082$

Current = $(39.64)(2.5) = 99.1$

Volt Amperes = $(99.1)(2082) = 206,300$

Wattmeter Reading = 53

Indicated Watts = $(53)(39.64)(19.94)$

= 41,893

Indicated $pf = \cos \theta_2 = 41,893/206,300$

= 0.20306

$\theta_2 = 78$ degrees 17 minutes

θ_2 , the indicated angle of lag, includes the phase angle of the wattmeter, α ; the phase angle of the current transformer, β ; and the phase angle of the voltage transformer, γ . If

$$\alpha = -1'$$

$$\beta = +55'$$

$$\gamma = +38'$$

then θ , the actual lag angle, = $\theta_2 - \alpha + \beta - \gamma = 78^\circ 17' - (-1') + (+55') - (+38') = 78^\circ 38'$

Actual $pf = \cos \theta = 0.1979$

$$\text{PACF} = \frac{\cos \theta}{\cos \theta_2} = \frac{0.1979}{0.20306} = 0.9747$$

Actual Power = $41,893 \times 0.9747 = 40,834$ W

3.2 Energy Measurements

3.2.1 Description

It is often desirable to check the energy consumption of electric power equipment by direct measurements with energy meters. A device that measures electrical energy is known as a watthour meter.

3.2.2 AC Solid-State Watthour Meters

One type of an ac watthour meter consists of a watthour transducer that uses the principle of the time-division multiplier. The time-division multiplier principle was explained in paragraph 3.1.2.2.

For energy measurement, a timing source is required. This is usually provided by a highly stable, internal quartz crystal oscillator. Time and power signals are converted to output pulses, the number of counts being directly proportional to energy, by integrating via operational amplifiers. The final output is displayed on a digital read-out. Accuracies of this type of watthour meter are usually in the range of a few hundredths of 1% (10^2 ppm).

3.2.3 Induction Watthour Meters

Induction-type watthour meters are basically induction motors with the following essential parts:

- 1) The rotor, which consists of an aluminum disk mounted on a shaft that is free to rotate;
- 2) The stator, which consists of voltage coil and a current coil wound on laminated iron cores;
- 3) A braking magnet, which generates a torque that opposes disk rotation; and
- 4) A revolution counter.

The voltage and current coils produce fluxes that induce eddy currents in the aluminum disk. With proper space and phase displacement the interaction between these fluxes and the eddy currents will generate a rotational torque on the disk. The space displacement is achieved by a suitable arrangement of the coils and laminations, such as shown in Fig 3-7. A 90° phase displacement is realized in part by the fact that the voltage coil is highly inductive. The remaining phase shift is obtained by a compensating coil and resistor that is magnetically coupled to the voltage coil.

Induction watthour meters are frequency dependent and may have accuracies approaching 0.1%. Power for their operation is derived from the circuit in which they are connected.

In the induction watthour meter, as the disk rotates, the flux lines generated by the permanent magnet are cut. A voltage is generated in the disk which results in eddy current flow. The eddy currents react with the permanent magnet flux to produce a retarding torque that is proportional to the speed of the disk.

Considering these relationships, if

$$\text{driving torque} \propto \text{power (watts)}$$

and

$$\text{retarding torque} \propto \text{disk speed}$$

For steady-state conditions:

$$\text{driving torque} = \text{retarding torque}$$

Therefore:

$$\text{power (watts)} \propto \text{disk speed}$$

and

energy \propto number of disk revolutions

Each disk revolution of a watthour meter represents a finite amount of energy in watthours, as defined by the value given on a meter nameplate as the disk constant, K_f .

The register on a watthour meter totals the number of revolutions the disk makes through a mechanical gear train. A register generally shows kilowatthours (kWh), with the smallest division on the units dial being 1 kWh.

3.2.3.1 Induction-Type Meter Adjustments and Compensations

Induction-type meters have three main adjustments: full load, light load, and power factor. For modern meters, the rated current is shown on the nameplate as Test Amperes (TA). This adjustment is accomplished by varying the retarding (or braking) magnet flux cutting the disk, normally by moving a shunting device via a screw adjuster.

An adjustment with light load on a meter is necessary to compensate primarily for nonlinear variations in the magnetic characteristics of the electromagnetic core. To compensate, a short-circuited copper circuit or tin copper punching ("shading-strip") is placed in the potential-pole air gap in an unsymmetrical position. As a result, a slight forward torque is created that can be varied to provide sufficient compensation. This adjustment is made at 10% of Test Amperes (TA) at unity power factor with rated voltage.

To correctly measure watthours, an exact 90° displacement between the current coil flux and the voltage coil flux is necessary. In consequence of the ohmic resistance of the voltage coil, the current is never exactly 90° behind the impressed voltage. This displacement is completed by the power-factor adjustment. A short-circuited lag plate or a lag coil, usually on the voltage-coil laminations or immediately below, is mounted so that the voltage coil flux induces in it a voltage that causes a small current to flow, which, in turn, produces a new flux. This lag-coil flux causes the resultant disk flux to lag exactly 90° . This lag compensation may be changed in some meters by a resistor pigtail solder means or by a screw adjustment in others. This adjustment is usually made with Test Amperes (TA) and rated voltage at 50% power factor, lagging current. In some modern meters, this adjustment is made in a permanent manner at the factory and no field adjustment is possible.

3.2.4 Three-Wire and Four-Wire Circuits

All of the foregoing discussion has covered one measuring element for energy measurement. This type of device would be applicable to two-wire single-phase circuits. Circuits with three and four wires require additional measuring elements or meters.

Blondel's Theorem, requiring $n - 1$ measuring elements, is explained in paragraph 3.1.4.1 and also applies to the connection diagrams of watthour meters. In electromechanical meters, the summation of powers is usually accomplished by mounting individual elements on a common shaft and, of course, with solid-state meters, the summation is done by electronic means.

To facilitate three- and 4-wire metering, commercial watthour meters are made in various forms that violate Blondel's Theorem by assuming reasonably balanced voltages. Among these are a one-stator meter for 3-wire single-phase circuits; and two-stator meters for 4-wire 3-phase wye and delta circuits.

Portable standard watthour meters are usually available only in the single-phase form. Hence, for testing purposes, polyphase circuits may be metered by connecting two or more standards into the circuit in exactly the same manner as wattmeters. The use of single-phase meters or standards has the advantage of giving further data, such as balance of load and average power factor, and the correction for instrument-transformer errors can be made more accurately and directly.

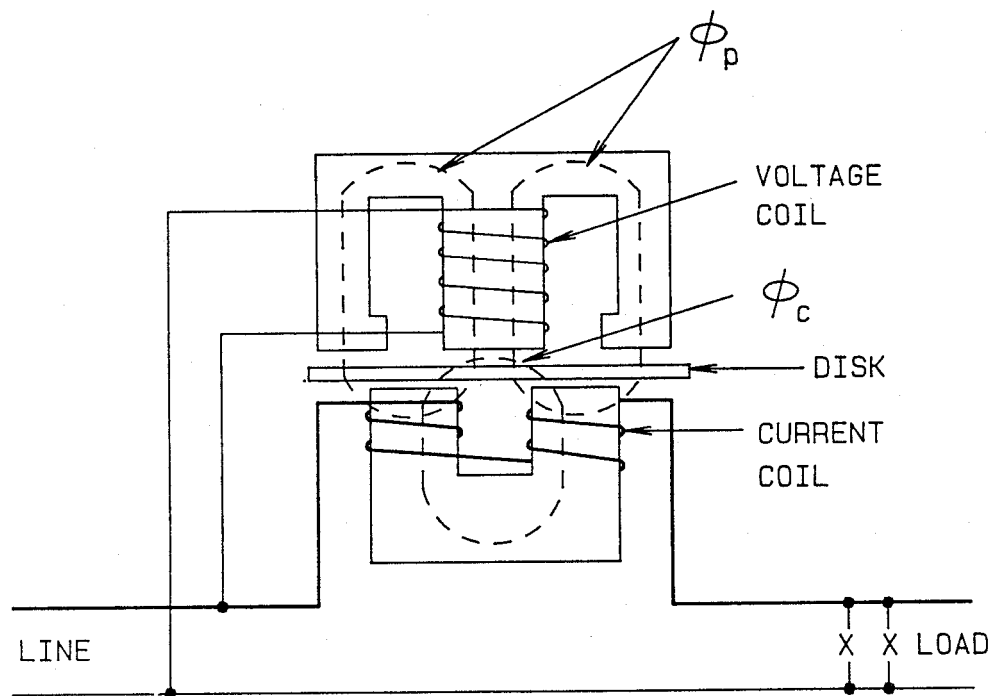

Figure 3-7—Stator of Electromechanical Watthour Meter

3.2.5 Demand Measurement of Electric Energy

Measurements of average power over a specified short time interval, or demand, may be required in some tests. To do this, the elapsed time must be accurately determined. The meter should be allowed to run continuously, and the exact time for a definite number of revolutions may be determined with a stop-watch reading to fractions of a second, if the interval is short, or an ordinary watch reading seconds, for longer intervals. The important point is to observe both revolutions and time with sufficient precision to keep the observational error small, preferably 0.2% or less. From the number of revolutions, the watthours are determined by multiplying by the disk constant, K_h . Dividing by the measured time in hours gives the average watts. All of these measurements are performed automatically by using a commercial meter equipped with a demand register. The timing in a demand register is done by either a synchronous motor in electromechanical registers or electronically in solid-state registers. In general, the time intervals used are either 15, 30, or 60 min, depending on design. The maximum demand is generally indicated in kilowatts, being the average power over the time interval selected.

3.2.6 Application of Service Meters and Standard Meters

The regular service-type of meter is applicable to a test that extends over a long time and where the change in the register readings is sufficiently great so that the observational errors are reduced to permissible percentage of the difference between the readings. For example, if the register can be read to only 1 kWh, and the difference between the initial and final readings is 100 kWh, the observational error would be 1%—an error that would be permissible where only approximate results were desired.

In general, watthour meters of the regular service-type, with standard registers, do not permit sufficiently precise readings for plant tests. A greater resolution may be obtained by using a watthour meter equipped with a pulse generator and a pulse counter or recording equipment. Pulse output of eight pulses per disk revolution are common. The ratio of pulse-to-disk revolutions should be selected to match the particular needs of the application.

The ordinary service-type of meter may be used by disregarding the register and counting the revolutions of the disk by direct observation. The disk may be marked off in quarters or tenths to get the necessary accuracy with a small number of revolutions.

In standard or reference watt-hour meters, the revolutions of the rotating element are registered directly, and the number of revolutions multiplied by the watt-hours per revolution gives the energy that has passed through the meter in the elapsed time. Such meters can be read to a high degree of accuracy, but at rated load for long runs the register reading may repeat, making it necessary to keep a tally of the number of repeats. Solid-state watt-hour meters with pulse outputs may be used in conjunction with recorders, counters, or printers. Pulse rates of 6 000/h at rated capacity are common. Higher rates are available.

3.2.7 Rating

The rating of the meter should be such that it will operate at loads well removed from the light-load part of the load curve. Tests should not be performed with currents below that of the test-ampere value. The maximum current rating of modern commercial meters is given by the class rating as given on the nameplate; e.g., a Class 100 meter will perform accurately up to 100 A.

3.2.8 Temperature

The meter should be in the circuit sufficiently long before readings are taken to ensure uniform and constant temperature throughout. This is ordinarily not less than one-half hour for induction-type meters. When ordinary service meters are used for testing purposes, the cover should be left on to ensure uniform temperature and also to eliminate the effects of air drafts, dust, etc., a special aperture being provided, if necessary, to view the rotating disk.

3.2.9 Calibration of Watt-hour Meters

Watt-hour meters are customarily calibrated by determining the percentage registration, that is, the percentage of the energy passed through the meter in a short time interval. This may be done by two methods:

- 1) By precise timing of a number of revolutions of a meter while holding the watt input constant during the period, or
- 2) By operating the meter for a preselected number of revolutions simultaneously with a calibrated portable watt-hour standard of higher accuracy than the meter.

For the first method, the watt-hours registered in a given time are noted while the average power is simultaneously measured during the same period with a standard wattmeter. Since the energy represented by one revolution, or the watt-hour constant, has been marked on the nameplate, the watt-hours registered by the meter on a given period will be $K_h \times R$, where K_h is the watt-hour constant and R is the number of revolutions. The accuracy of the gear ratio between the rotating element and the first dial of the register can be determined by count.

The percent registration is then readily computed. Thus,

$$\begin{aligned} \text{percent registration} &= \frac{\text{meter watt-hours}}{\text{true watt-hours}} \times 100 \\ &= \frac{K_h \times 3600 \times R}{s \times W} \times 100 \end{aligned}$$

where

$$\begin{aligned} K_h &= \text{watt-hour constant} \\ 3600 &= \text{number of seconds in 1 hour} \end{aligned}$$

- R = revolutions in the test period of s seconds
 W = true average power in watts during the test period as measured with indicating instruments

The last formula is the standard formula used in testing watthour meters.

The constant marked on the nameplate by some manufacturers may be other than the watthour constant. This should always be checked before proceeding with the calibration. Very complete information regarding meter constants and other meter data, may be found in the current edition of the *Electrical Metermen's Handbook* [3],⁷ published by the Edison Electric Institute, Washington, DC. Additional data on testing may be found in meter manufacturers' literature and ANSI C12.1-1988, American National Standard Code for Electricity Metering [1].

3.2.9.1 Source of Energy

The source of energy for meter testing should be as steady as possible. A regular meter test board may be used for the voltage and current sources or the testing load may be banks of lamps or rheostats in series with which the meter and the standard instruments are connected. A preferable method is to separate the current and potential circuits and connect them to independent sources, the former being a relatively large-current, low-voltage source and the latter, a high-voltage, low-current source. Conditions are more easily adjusted by this method and, with large meters, a saving of energy is effected.

3.2.9.2 Polyphase Meter Calibration

These meters are usually tested as single-phase meters by connecting the current circuits in series and the voltage circuits in parallel. It should be first determined, however, that the elements are equal in accuracy (balance) by testing each separately. An adjustment is usually provided for correcting unbalance by changing the reluctance of the path of the flux from one of the current electromagnets. Reference to meter manufacturers' literature will provide more detailed test connections and procedures for polyphase meter calibration.

3.3 Power Factor and Phase-Angle Measurement

3.3.1 General

In a circuit, power factor is the ratio of the total active power to the total apparent power:

$$pf = \frac{P}{S}$$

The power factor is a figure of merit, indicating how much of the total apparent power, flowing into a load or a feeder is active power, P .

3.3.2 Direct Measurement

Analog Meters — Such instruments employ a current coil (the stator) and a rotor, which usually has two coils, each connected in series with an impedance. No restraining spring is used. The moving system (the rotor) takes an equilibrium position when the resultant torque generated by the coils is nil. The angle of rotation is a function of the phase angle.

Such meters can be used only in networks with sinusoidal waves. In polyphase systems, the readings are correct on a balanced load only.

⁷The numbers in brackets correspond to those of the bibliography at the end of this chapter.

3.3.3 Digital Meters

Units based on zero-crossing detector.

By measuring the time lapsed between the moments when the voltage wave and the current wave cross the zero level it is possible to know the phase angle θ . For sinusoidal waves only $pf = \cos \theta$.

Modern data acquisition systems have the capability to measure P and S and compute pf . Moreover, units based on Fast Fourier Transformation will compute the harmonics spectrum and, for each voltage and current harmonic, the amplitude and the phase angle will be displayed or recorded.

3.3.4 Indirect Measurement of pf .

In Fig 3-4 is shown a complete circuit that enables the calculation of pf

$$pf = \frac{W_1 + W_2 + W_3}{V_1 I_1 + V_2 I_2 + V_3 I_3}$$

In balanced 3-phase, 3-wire sinusoidal circuits (Figs 3-2 and 3-5) using two wattmeters:

$$pf = \cos \left[\arctan \frac{\sqrt{3}[W_1 - W_2]}{W_1 + W_2} \right]$$

where W_1 is the larger reading (always positive) and W_2 the smaller.

Industrial loads are sometimes monitored by kilowatt-hour meters (kWh) and kilovoltampere hour meters (kVAh). The ratio of these two readings kWh/kVAh gives a crude estimate of the load pf .

3.4 Transducers

A useful category of instruments used for measurement of power phase angle or power factor are the transducers. The connection of these devices to the power systems follows the same recommendations and uses the same circuits as the one presented in the previous paragraphs. The output of transducers is a dc signal of a few millivolts or volts, proportional to the power (watts, voltamperes, or vars), phase angle, or power factor.

The dc signal can be measured with the help of an analog or digital voltmeter, can be displayed by means of a recording instrument or can be supplied to an analog-to-digital converter and processed to a computer.

For more details on transducers, see 7.1 of this standard and ANSI/IEEE Std 460-1988, IEEE Standard for Electrical Measuring Transducer for Converting AC Electrical Quantities into DC Electrical Quantities [2].

3.5 Bibliography

- [1] ANSI C12.1-1988, American National Standard Code for Electricity Metering.⁸
- [2] ANSI/IEEE Std 460-1988, IEEE Standard for Electrical Measuring Transducer for Converting AC Electrical Quantities into DC Electrical Quantities.
- [3] *Electrical Metermen's Handbook*. 8th edition. EEI Pub. No. 06-81-02. Washington, D.C.: Edison Electric Institute.

⁸ANSI C12 and ANSI/IEEE publications are available from the Institute of Electrical and Electronics Engineers, Service Center, 445 Hoes Lane, Piscataway, NJ 08855-1331, or from the Sales Department, American National Standards Institute, 1430 Broadway, New York, NY 10018.

4. Chapter 4—Frequency Measurements

4.1 Description

The frequency of an alternating current is the number of complete cycles per second, or the number of alternations per second divided by two. For the ordinary alternator, the frequency is

$$f = \frac{pn}{2}$$

where

$f =$	frequency in hertz
$p =$	number of poles on the field of the generator
$n =$	revolutions per second

When the generator is readily accessible, often the simplest way to determine the frequency is to note the number of poles on the generator and measure its speed. The frequency can also be measured by means of instruments that are connected directly to the circuit. They have an additional advantage that, being indicating instruments, the frequency is shown at every instant. There are four principal types: digital-crystal-controlled type, mechanical resonance or vibrating-reed type, moving-coil type, and moving-vane type. Also refer to the oscilloscope in 7.2.

4.2 Methods of Measuring Frequency

4.2.1 Digital Frequency Counter

Digital frequency counters that display the frequency on digital readouts are electronic counters that measure the period of one or more cycles of the signal being checked against the output of very stable temperature controlled oscillators. The inverse of the period for one cycle is the frequency in hertz. These instruments are available commercially with resolutions from 1-0.001 Hz. The range of frequency measurement is from dc to 1300 MHz or higher.

These instruments may be used for portable test equipment or for permanent mounting in switchboards.

4.2.2 Frequency Transducers

Frequency transducers have an analog dc output proportional to frequency and may be used with an indicated milliammeter or recorder. Analog-to-digital converters may also be used for digital readouts. Range of measurement is usually limited: 55–65 Hz for a 60 Hz transducer.

4.2.3 Vibrating-Reed Frequency Meter

A row of narrow strips of steel of varying lengths, attached at one end to a common support and with the other end free to move, is located in the field of an electromagnet that is energized from the circuit under observation. The strips have different natural periods; the one with a period most closely corresponding to the alternations of the magnetic field (and, therefore, the circuit to which it is connected) will be set in vibration. The reeds are horizontal with the ends turned up and painted white so that, when a particular reed vibrates, a white band is formed. The fine adjustment of the natural period of each reed is obtained by adding a minute weight at the end.

4.2.4 Moving-Vane Frequency Meter

This type is shown in Fig 4-1 where 1,1 and 2,2 are fixed coils, 90° apart, and c,c is the movable element consisting of a soft iron core mounted on a shaft, free to move with no restraining torque. Coil 2, 2 is connected in series with a noninductive resistance R_2 , and coil 1, 1, in series with an inductance X_1 . A second noninductive resistance R_1 is connected in parallel with 1, 1 and X_1 . A second inductance, X_2 , is connected in parallel with 2, 2 and R_2 . The soft iron core takes up the position of the resultant field produced by the two coils. When the frequency increases, the current decreases in 1., 1. and increases in 2., 2., thus shifting the direction of the resultant field and the pointer position. The series inductance X serves merely to damp the higher harmonics that are present if the voltage wave shape is distorted.

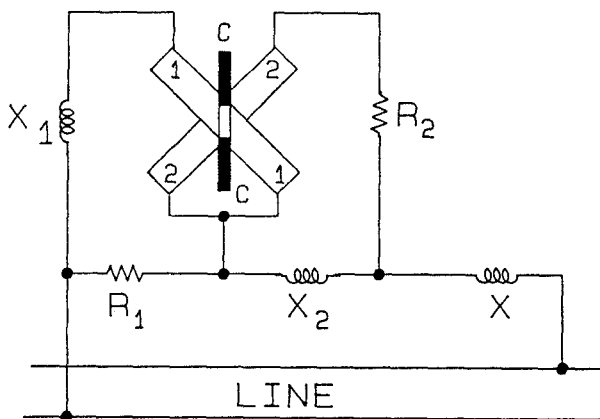

Figure 4-1—Circuit of the Moving-Vane Frequency Meter

4.2.5 Moving-Coil Frequency Meter

This type is similar to the moving-vane type except that two coils rigidly fastened together form the moving system and a single fixed coil is the stationary member.

4.2.6 Measurement of High Frequencies

Where great accuracy is not required, measurement of high frequencies can be made with a wave or frequency meter shown diagrammatically in Fig 4-2. The RLC circuit equipped with some indicating device is loosely coupled to the circuit, the frequency of which is to be measured.

Maximum current is first obtained by proper adjustment of L or C . Theoretically, the resonant frequency can be calculated from the circuit parameters that yield maximum current, but usually the device is calibrated against some form of standard frequency meter. The frequency that is to be measured is then determined by reference to a calibration chart for the particular values of L and C employed to give maximum current in the RLC loop. The device depends upon being sufficiently loosely coupled so that no appreciable reaction in the test circuit results from the current in the RLC loop.

High frequencies can also be measured either directly by means of a cathode-ray oscillograph with a calibrated time base or by means of comparison with a frequency standard.

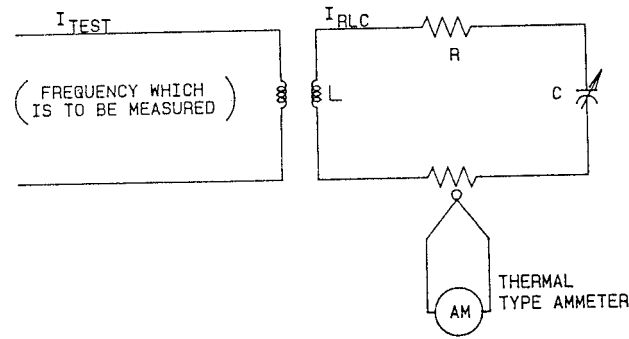

Figure 4-2—Wave Meter Method of Measuring High Frequencies

4.2.7 Relative Advantages

Frequency meters of the moving-vane and moving-coil types, being pointer instruments, give a continuous indication of the frequency that is easily interpolated, while the reed type gives indications corresponding primarily to certain fixed values—say one-fourth or one-half cycles apart. However, the pointer instruments are appreciably affected by waveform changes, while the reed type is only very slightly affected; furthermore, with a little practice, one can interpolate readily to half-intervals on a reed-type frequency meter, or even more closely if the frequency changes slowly and the initial calibration adjustment of the individual reeds has been carefully performed. Pointer type frequency meters are especially suitable for switchboard use, while the reed type is preferable for checking switchboard frequency meters and for laboratory use because it is practically independent of wave form and has a low temperature coefficient ($0.01\%/^{\circ}\text{C}$).

Digital frequency counters have the advantage of direct display of the frequency reading to the resolution capabilities of the counter.

4.3 Calibration

Frequency meters are calibrated by connecting them to a frequency reference source or signal generator. The voltage applied to the instrument should be approximately the same as that in the test and it should be applied to the instrument long enough to heat it to the operating temperature, unless the instrument is for intermittent use only, in which case the voltage is applied only long enough to secure a reading. In general, high accuracy in frequency measurements is not required in power tests.

5. Chapter 5—Impedance Measurements

5.1 Description

The effective magnitude of the impedance, Z_e , of a circuit depends upon the circuit parameters, R (resistance), L (inductance), M (mutual inductance), and C (capacitance). The effective magnitude of these parameters is often influenced by temperature, frequency, potential gradient, current density, and flux density. The impedance of a circuit should, therefore, be measured under conditions that are as nearly identical to actual operating conditions as possible. The complete description of impedance at a specific frequency is

$$Z_e = \sqrt{R_e^2 + X_e^2}$$

5.2 Determination of Impedance

The impedance of high-power circuit elements can be evaluated directly from experimentally determined values of voltage, current, and power, after applying corrections for errors introduced by the insertion of the instruments in the circuit.

In making either voltage or current corrections, due consideration must be given to the phasor relations of the quantities involved. If the wattmeter potential circuit and the voltmeter are connected on the load side of an uncompensated wattmeter current coil, as shown in Fig 5-1, the V^2/R loss in the potential circuits must be subtracted directly from the wattmeter reading to obtain the correct power, W , absorbed by the load.

Then, the impedance can be calculated from $Z_e = V/I$.

5.2.1 Ground Impedance

Connections to earth are generally complex impedances having resistive, capacitive, and inductive components. The characteristics and methods of measuring ground impedance are discussed in ANSI/IEEE Std 81-1983, IEEE Guide for Measuring Earth Resistivity, Ground Impedance, and Earth Surface Potentials of a Ground System [1]⁹.

5.3 Effective Resistance

The effective resistance, R_e , of a circuit is defined as the ratio of the power, W , to the square of the current, I , in the load.

$$R_e = \frac{W}{I^2}$$

For example, the effective resistance of the load impedance shown in Fig 5-1 can be determined directly from the corrected readings of the ammeter and wattmeter. R_e , as found from the above equation, may differ materially from the ohmic or dc resistance. This is due to any or all of the following: skin effect, electromagnetic or electrostatic coupling with other circuits, or the (proximity of) magnetic or dielectric material.

The various methods of measuring resistance and the application of these methods in determining the performance of electric machines is covered by IEEE Std 118-1978, IEEE Standard Test Code for Resistance Measurements [2]. IEEE Std 118-1978 discusses the special techniques required for measurement of very low and very high resistances, and for

⁹The numbers in brackets correspond to those of the bibliography at the end of this chapter.

measurement of resistance at high and low currents and voltages. Methods described involve the use of voltmeters, ammeters, ratio devices, bridges, comparators, and ohmmeters.

5.4 Effective Reactance

The effective or equivalent series circuit reactance of a network or circuit is defined as

$$X_e = \sqrt{Z_e^2 - R_e^2}$$

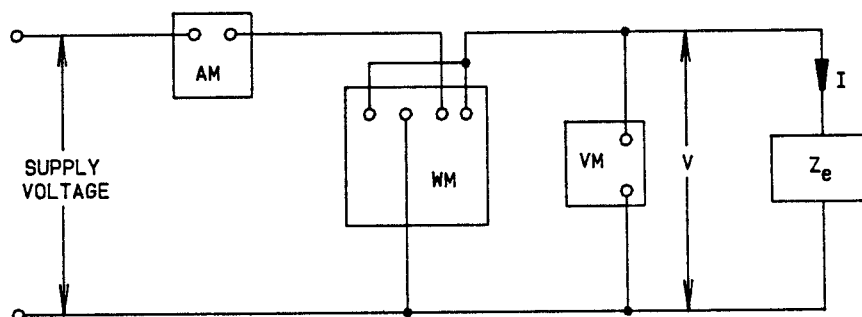

Figure 5-1—Method of Determining the Impedance

The magnitude of X_e can be evaluated from the above equation after having determined Z_e , effective impedance, and R_e , effective resistance, from physical measurements of voltage, current, and power.

The reactance of a circuit may be inductive or capacitive depending on the magnitude of the various circuit parameters. To determine whether a circuit is inductive or capacitive, a phase angle measurement should be made to determine if the current phasor lags or leads the voltage phasor.

5.4.1 Inductance

The self-inductance or coefficient of self-induction, L , of a circuit is the constant by which the time rate of change of the current in the circuit should be multiplied to give the self-induced counter emf. Similarly, the mutual inductance, M , between two circuits is the constant by which the time rate of change of current in either circuit should be multiplied to give the emf thereby induced in the other circuit. Self-inductance and mutual inductance depend upon the shape and dimensions of the circuits, the number of turns, and the nature of the surrounding medium.

5.4.2 Capacitance

The electrostatic capacitance, C , of two conductors separated by a dielectric is measured by the electrostatic flux which is stored in the dielectric when a given potential difference is maintained between the conductors, which flux in turn depends upon the surface area of the conductors, the distance between them, the character of the dielectric, and to some extent, on the temperature and the pressure.

5.5 Difficulties Encountered in Making Measurements

In many cases it is practically impossible to measure circuit parameters, R , L , M , and C by means of the voltmeter-ammeter-wattmeter method. In low-power circuit elements, the allowable current may be too small to successfully operate an electromechanical wattmeter or ammeter. In other cases the circuit may be so radically disturbed as a result of the introduction of instruments that the measurements made are useless insofar as original circuit parameter

determination is concerned. Electronic devices, which are sometimes employed to measure voltage, current, and power, draw very little or no power from the circuit that is under investigation, and for this reason they are useful adjuncts to normal metering equipment in certain cases. However, precautions should be taken to ensure that the meters are accurate with respect to the wave shape in the test circuit.

5.6 Bridge Methods

Bridge methods are generally to be preferred in making measurements involving low-power circuit elements. This is particularly true if the effective values of the parameters are to be determined at frequencies ranging from 200–2500 Hz. Self-contained impedance bridges are commercially available.

Alternating-current bridges, which take the same general form as the familiar dc Wheatstone bridge, can be used to measure inductance—both mutual and self-inductance—and capacitance. A simple form of ac bridge is shown in Fig 5-2. Many of the bridges employed in practice contain two resistance arms and two impedance arms. For best results the two resistance arms are accurately calibrated resistances that are wound so as to reduce self-inductance and self-capacitance effects. To obtain greatest flexibility the resistance arms are adjustable, but for certain operating conditions they may take the form of fixed resistances. The other two arms of the bridge are the impedance arms: one, the standard impedance ($R_s + jX_s$); the other, the unknown impedance ($R_x + jX_x$) that is to be measured.

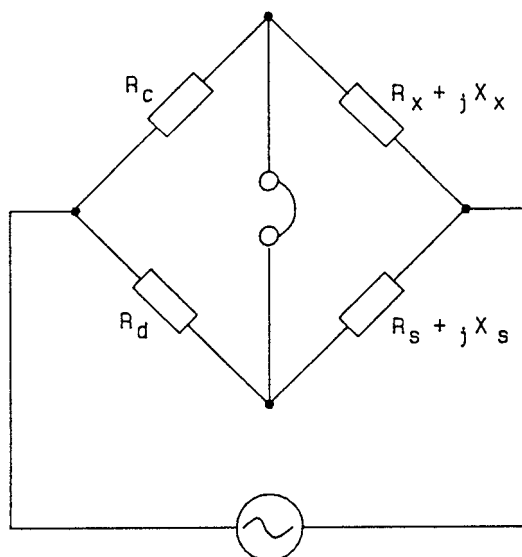

Figure 5-2—Similar-Angled Bridge

After adjustments of R_c , R_d , R_s , and X_s have been made so that no potential difference exists between points c and d , then:

$$R_x = \frac{R_c}{R_d} R_s$$

and

$$X_x = \frac{R_c}{R_d} X_s$$

This last equation shows that, if the unknown impedance is inductive in character, the standard impedance must also be inductive in character. If the unknown impedance is capacitive in character, then the standard impedance must also be capacitive in character provided that the arms are arranged as shown in Fig 5-2.

If the reactive element of the unknown impedance is opposite in nature to the reactive element of the standard impedance, then the bridge arms R_c and $(R_x + jX_x)$ must be interchanged. Bridges of this general class are called opposite-angle bridges.

5.6.1 Detectors Used in Bridge Methods

Detectors used in bridge measurements of inductance and capacitance are selected according to the test frequency and the impedances being compared. The commonly used detectors are tuned amplifiers and phase-locked amplifiers. For less critical measurements, an oscilloscope or an indicating meter connected to the output of an amplifier can be used.

5.7 Bibliography

[1] ANSI/IEEE Std 81-1983, IEEE Guide for Measuring Earth Resistivity, Ground Impedance, and Earth Surface Potentials of a Ground System.¹⁰

[2] IEEE Std 118-1978, IEEE Standard Test Code for Resistance Measurements.

¹⁰ANSI/IEEE publications are available from the Institute of Electrical and Electronics Engineers, Service Center, 445 Hoes Lane, Piscataway, NJ 08855-1331, or from the Sales Department, American National Standards Institute, 1430 Broadway, New York, NY 10018.

6. Chapter 6—Measurements of Magnetic Quantities in Power Circuits

6.1 Description

The performance of a magnetic device or system under test is a function of four magnetic quantities: (1) magnetic flux density, B ; (2) magnetic field strength, H ; (3) magnetic flux, Φ ; and (4) permeability, μ .

In addition to the SI units, cgs (centimeter-gram-second) systems are frequently used in magnetic measurements. The units used for B , H , Φ , and μ , and the conversions between the SI and the cgs systems are given in Table 6.1.

These quantities are related to each other as follows: $\Phi = BA$, where A is the area in a magnetic field through which Φ is established. (It is assumed that B is constant over this area.) $B = \mu H$, where μ is the permeability of the air or electrical steel through which Φ is established.

The location chosen to measure these magnetic quantities in the magnetic circuit of the device under test influences the type of instrument used and whether the quantities are measured directly or indirectly. There are three different locations where making measurements may be desired:

- 1) in air,
- 2) in the steel used in a magnetic device, and
- 3) in the permanent magnet(s) of a permanent magnet device.

The instruments currently manufactured in the U.S.A. for the measurement of the above four magnetic quantities provide readings in the cgs units.

Table 6.1—Conversion Table for Frequently Used Magnetic Measurements

Quantity	cgs	SI	To convert from	To	Multiply by
Flux density, B	gauss, G	tesla, T	gauss	tesla	1.000×10^{-4}
Magnetic field, H	oersted, Oe	amperes per meter, A/m	oersted	ampere per meter	7.958×10^1
Flux, Φ	maxwell, Mx	weber, Wb	maxwell	weber	1.000×10^{-8}
Permeability, μ	gauss/oersted	henry per meter, H/m	gauss/oersted	henry per meter	1.257×10^{-6}

6.2 Measurements in Air

6.2.1 Measurements of B and H in Air

Many times it is desired to measure B and H in the working air gap of a motor, a choke, etc., or in the air adjacent to the magnetic device under test. There are three types of instruments, all portable, that are commonly used in these locations. The Hall-effect gaussmeter and the fluxmeter are of comparable accuracy, while the moving permanent magnet gaussmeter is considerably less accurate. Although these three instruments indicate B in gauss, they also will indicate H measured in air, because in air $\mu=1$ to within 0.1%. The only conversion required is to substitute oersted for gauss for these instruments to measure H in air.

6.2.1.1 Hall-Effect Gaussmeter

This instrument is commonly called a Hall gauss-meter and consists of two sections: (1) the sensor, usually called a Hall probe, and (2) the indicator. There are transverse probes and axial probes that are used to measure the magnitude

and direction of lines of B . The transverse probe is used for lines that are perpendicular to the plane of the probe, which plane includes the axis of the probe. The transverse probe must be turned about its axis until the reading is maximum. The axial probe is for lines that are parallel to the axis of the probe. Both probes respond to either steady or alternating magnetic fields.

The indicators to which these probes are connected indicate the sensed B and are powered either from self-contained batteries or the ac line. Generally, these indicators are multi-ranged with a low range of 0-1 G and a high range of 30 000 G, with an accuracy of $1/4\%$. For power circuits 30 000 G is more than adequate. However, special Hall probes are available that permit the indicator to function up to 150 000 G for cryogenic devices.

The indicators, as well as the probes, are made for steady or alternating fields. Combined frequency response up to 20 kHz are available for the probe and the indicator. However, as the resistance of the Hall effect element changes with temperature, the indicated gauss reading becomes temperature-dependent. This effect can be eliminated by techniques that reduce the response of the instrument to the range of of 400–500 Hz.

6.2.1.2 Fluxmeter

This instrument is an extremely stable and linear integrator that integrates the voltage induced in a flux coupling coil or sensor, usually called a search coil, connected to the input terminals of the fluxmeter. The voltage, V , induced in a coil that is placed in a time varying magnetic field is $V = NAdB/dt$ where N is the number of turns in the coil and A is the area of this coil. This relationship can be rewritten to yield $\int Vdt = NA(\Delta B)$. From this equation it can be seen that the time integral of the voltage induced in the coil is proportional to the change in B at its location.

The leads from the flux coupling coil should be twisted to eliminate the effect of stray magnetic flux linking these leads and producing errors. The plane of the coil should be positioned to obtain the maximum reading, which yields the correct value.

Because a fluxmeter measures the change in B , one way that a dc measurement can be made is by turning on and off the magnetic device under test, which causes B to go from approximately zero to its operating level. If the fluxmeter is zeroed when the power to the magnetic device is off, then the instrument will indicate the operating level of B when power is applied. Whenever possible, the accuracy of measuring B can be improved by reversing the applied voltage on the device under test which causes the change of B to be twice the operating level of B . Reversing the applied voltage and measuring the change in B from full voltage of one polarity to full voltage of the reverse polarity eliminates the effects of residual magnetism. Another technique is to zero the fluxmeter while the search coil is in a zero magnetic field and then place the search coil in the magnetic field to be measured.

When it is used to measure the flux produced by ac systems, the search coil is kept stationary after positioning it to obtain the maximum reading.

If the device under test is of the permanent magnet type, it may not be possible to turn it off. Then a change in B through the search coil can only be accomplished by zeroing the fluxmeter when the coil is not in the vicinity of the device and then placing the coil where the measurement of B is wanted. The resulting change in B passing through the coil, which is indicated by the fluxmeter, is the measured B .

The fluxmeter controls are organized so as to display the average flux density across the area of the coil or the total flux within the coil. Input dials provide for setting in the area-turns of the coil or only the number of turns. The indicating meters have either analog or digital displays with readings in the cgs system. An output signal from zero to one volt proportional to the meter readings is also available.

These instruments have ranges from 10^4 to 10^9 Mx turns with accuracies as great as $1/4\%$ for dc measurements. They will respond to input pulses with rise or fall times (10–90%) as fast as 10 μ s. Uncompensated thermocouple voltages, which are usually present at the instrument's input, are removed by adjusting a zero control for minimum drift of the integrator. The resulting drift can be as low as 100 Mx turns per minute. For ac fields these instruments will yield rms

values of B for frequencies from 10 Hz to 100 kHz with accuracies as high as $1/2$ of full scale. These instruments can operate from a 50/60 Hz ac power line or internal batteries.

6.2.1.3 Permanent Magnet Gaussmeters

The permanent magnet gaussmeter consists of a small, high-coercive-force magnet attached to a shaft that has a pointer and a spiral spring fastened to it. The instrument is similar to a pivot-and-jewel meter movement. In operation, the shaft with magnet attached is placed in the magnetic field that is to be measured, and the entire measuring device is rotated until maximum reading is obtained. The field being measured then is equal to the reading on the scale in gauss with an accuracy of 5% of full scale. Ranges are available from ± 15 G to several thousand gauss.

6.2.1.4 Other Gaussmeters

There are several other devices for measuring flux density in air. The well known ones are

- 1) The rotating-coil gaussmeter,
- 2) The fluxgate magnetometer, and
- 3) The nuclear magnetic resonance gaussmeter. However, they are much less portable and more difficult to apply for measurements in power devices; consequently, their use for such measurements is not recommended.

6.2.2 Measurement of Φ in Air

The equation in 6.2.1.2 relating V and $d\Phi/dt$ can also be written as $\int V dt = N(\Delta\Phi)$. Thus the time integral of the voltage induced in a flux coupling loop is equal to the change of flux passing through the coil times the number of turns in the coil. Therefore, the fluxmeter of 6.2.2 will also measure Φ in air, with the units of maxwells, as well as B . The same accuracies and drift characteristics apply for measuring Φ as well as B .

6.3 Measurements in Electromagnets

6.3.1 Measurement of B and Φ .

This measurement can only be accomplished using a fluxmeter and flux coupling coil (refer to 6.2.1.2). The coil is created by wrapping a known number of turns of wire around the cross section of the core of the magnetic device at the location where the measurement is to be made. The fluxmeter will indicate both B and Φ where B is the average value of B across this section of the core. The operation of the fluxmeter is described in 6.2.1.2.

6.3.2 Measurement of H .

Either a Hall probe or a flux coupling loop, placed as close as possible to the outside of the core, will measure the H required to produce the Φ and B existing in the core. Sections 6.2.1.1 and 6.2.1.2 describe how to use these two devices to make the desired measurement of H . The permanent magnet gaussmeter of 6.2.1.3 can also be used to measure H , but it is significantly less accurate. All three of these instruments are actually responding to the B in the air immediately adjacent to the core of the electromagnetic device. However, as $B = H$ in air in cgs units, these instruments also indicate H if oersteds are substituted for gauss.

6.4 Measurements in Permanent Magnets

6.4.1 Measurement of B and Φ

The only instrument that will measure B and Φ inside a material, other than air, is a fluxmeter with a flux coupling coil placed around the material. Unfortunately, as explained in 6.2.1.2, the fluxmeter only measures changes in flux and,

with a permanent magnet source of magnetic flux, it is usually impossible to change the flux levels. Consequently, it is usually impractical to make B and Φ measurements in permanent magnets.

6.4.2 Measurement of H

Either a Hall probe or a permanent magnet gaussmeter, when placed against the surface of the permanent magnet, will indicate the H required to produce the Φ and B existing in the magnet at the point of this measurement. Refer to the preceding section for the techniques employed.

6.5 Measurements of B , Φ , and H in Samples of Magnetic Materials

The measurement of the magnetic properties of representative samples used to construct magnetic devices can be made with the aid of magnetic permeameters. The individual samples are placed in the permeameter in order to make the desired measurement.

6.6 Measurement of Permeability in Electrical Steels or Magnet Iron

As stated in 6.1, $B = \mu H$, where μ is the permeability of the medium in which B exists. In the cgs system of units, $\mu = 1$ for air and can be as large as several hundred thousand for some special alloy electrical steels. The measurement of μ can be computed from measurements made in a permeameter as mentioned in the preceding section.

6.6.1 Low Permeability Indicator

There are permeability indicators available for use on materials with quite low permeability from 1.01 to 2.5. The indicators are simple nondestructive inspection instruments developed for acceptance testing of austenitic stainless and manganese steel. The indicators are available with inserts having permeabilities of 1.01, 1.02, 1.05, 1.10, 1.15, 1.2, 1.4, 1.6, 1.8, 2.0, 2.2, and 2.5 μ . The operation of one type of indicator is based on the mutual attraction of a permanent bar magnet for a known standard and an unknown material.

7. Chapter 7—Ancillary Instruments and Equipment

7.1 Electrical Transducers

7.1.1 Description

This chapter applies to transducers with an electrical input and output for making measurements of alternating electrical quantities. Much of the material is adapted from ANSI/IEEE Std 460-1988, IEEE Standard for Electrical Measuring Transducer for Converting AC Electrical Quantities into DC Electrical Quantities [1]¹¹.

Electrical transducers are devices that transform high-level ac electrical quantities into low-level dc currents or voltages for use as measuring or controlling signals for indicating, logging, and controlling devices or systems. They may be self-powered devices, obtaining operating power from the test signal(s), or auxiliary-powered devices, obtaining power from a separate power source. The most common measured quantities are current, voltage, active power, and reactive power. Transducers are also available for measuring apparent power, phase angle, power factor, and frequency. Pulse outputs, available on some transducers for integrating and/or transmission purposes, will not be covered in this chapter.

7.1.2 Scope

This chapter applies to transducers with an electrical input and output for making measurements of alternating electrical quantities. Within the effective range, a change of output is a function of the corresponding change of input that produces it. The output, which is in the form of a direct current or voltage, may be used as an input to a dc electrical measuring instrument, a process control system, a supervisory control system, or for other purposes. It does not cover transducers for measuring dc quantities, nonelectrical quantities, or those having other than a dc output.

7.1.3 Definitions

The following definitions are extracted from ANSI/IEEE Std 460-1988, IEEE Standard for Electrical Measuring Transducer for Converting AC Electrical Quantities into DC Electrical Quantities [1]. For a complete list and more details, refer to that standard.

7.1.3.1 Electrical Measuring Transducer: A device for converting an ac electrical quantity into a direct current or voltage for measurement purposes. Transducer types are as follows: voltage, current, watt (active power), var (reactive power), frequency, phase angle, and power factor. Each of these converts the indicated ac input quantity into a dc current or voltage output.

7.1.3.2 Distortion Factor: The ratio of the rms value of the harmonic content to the rms value of the nonsinusoidal quantity.

7.1.3.3 Output Load: The total resistance of the circuits and apparatus connected externally across the output terminals of the transducer.

7.1.3.4 Ripple Content of the Output: With steady-state input conditions, the peak-to-peak value of the fluctuating component of the output expressed as a percentage of the output span.

7.1.3.5 Output Power: The power available at the transducer output terminals.

7.1.3.6 Output Current (Voltage): The current (voltage) produced by the transducer which is an analog function of the measured quantity.

7.1.3.7 Response Time: The time from the instant of application of an input step until the output reaches and remains within 1% of the final value of its final value.

¹¹The numbers in brackets correspond to those of the bibliography at the end of this chapter.

7.1.3.8 Burden: The load imposed by the transducer on the measured circuit.

7.1.3.9 Nominal Value (Input or Output): A value, or one of the values, indicating the intended use of a transducer.

7.1.3.10 Output Span: The algebraic difference between the upper and lower values of the output range.

7.1.3.11 Input Span: The algebraic difference between the upper and lower values of the input range.

7.1.3.12 Fiducial Value: A value to which reference is made in order to specify the accuracy of a transducer. The fiducial value is the span except for transducers having a symmetrical reversible input and output. In this case, the fiducial value is half the span.

7.1.3.13 Maximum Permissible Values of Input Current and Voltage: Values of input current and voltage assigned by the manufacturer as those which the transducer will withstand indefinitely without damage.

7.1.3.14 Limiting Value of the Output Current (Voltage): The upper limit of output current (voltage) which will not, by design, be exceeded under rated or specified overload conditions.

7.1.3.15 Effective Range: That part of the span where the performance is intended to comply with the requirements of ANSI/IEEE Std 460-1988, IEEE Standard for Electrical Measuring Transducer for Converting AC Electrical Quantities into DC Electrical Quantities [1].

7.1.3.16 Rated Input: The nominal value of the input quantity measured or specified by the manufacturer.

7.1.3.17 Influence Quantity: A quantity (other than the measured quantity) that can cause unwanted variation in the output of a transducer.

7.1.3.18 Reference Conditions: A set of values assigned to the influence quantities used for determining the intrinsic accuracy of the transducer.

7.1.3.19 Nominal Range of Use: A specified range of values which it is intended that an influence quantity can assume without the output of the transducer changing by amounts in excess of those specified.

7.1.3.20 Error: The observed value of the output minus the true (ideal) value of the output.

7.1.3.21 Error Expressed as a Percentage of the Fiducial Value: One hundred times the ratio of the error to the fiducial value.

7.1.3.22 Intrinsic Error: The error determined when the transducer is under reference conditions.

7.1.3.23 Accuracy: The accuracy of the transducer is the sum of the intrinsic error and the variations due to influence quantities.

7.1.3.24 Operating Accuracy: The accuracy under a range of influence conditions typical of actual installed conditions.

7.1.4 Nominal Values for Transducers

7.1.4.1 Input Values

The nominal values of voltage, current, frequency, and auxiliary supply shall be agreed between the manufacturer and the user.

7.1.4.2 Output Values

Standard values of output current, voltage, and load resistance are specified in ANSI/IEEE Std 460-1988, IEEE Standard for Electrical Measuring Transducer for Converting AC Electrical Quantities into DC Electrical Quantities [1].

7.1.5 General Requirements for Transducers

7.1.5.1 Ripple Content

Unless otherwise agreed between the manufacturer and the user, the peak-to-peak ripple content in the output shall not exceed 2% of the output span.

7.1.5.2 Response Time

The response time is to be stated by the manufacturer. It is typically specified as < 400 ms for 99% of final value. Faster response is available in some transducers at the sacrifice of ripple content.

7.1.5.3 Limiting Value of the Output

When the measured quantity is not between its lower and upper nominal values, the transducer shall not, under any conditions within the manufacturer's maximum ratings, produce an output having a value between its lower and upper nominal values.

7.1.5.4 Temperature Limits of Operation

Unless otherwise marked, transducers shall withstand continuous operation when the ambient temperature is within the range of -17 to $+63$ °C.

7.1.5.5 Voltage Tests, Insulation Tests, and Other Safety Requirements

The requirements for voltage tests and other safety requirements in the ISA S82 series, [2], [3], and [4], apply to transducers covered by this standard.

7.1.6 Important Considerations in the Selection of Transducers

The following requirements need to be considered when selecting transducers:

7.1.6.1 Quantities to be Measured

Select transducers to measure the appropriate quantities: power (active and reactive), voltage, etc. It may be possible to take advantage of combined function transducers, such as watt/var, at a savings of cost and space.

7.1.6.2 Configuration of the Circuit to be Measured

Be sure that the transducer is matched to the circuit configuration, such as 3-phase 4-wire wye, 3-phase 3-wire delta, etc. Be aware that $1^{1/2}$ and $2^{1/2}$ element transducers operate with reduced accuracy except for conditions of balanced voltage. The $1^{1/2}$ element configuration further requires that the loads be balanced.

7.1.6.3 Input Voltage and Current Levels

Be sure that the transducer maximum input ratings will not be exceeded under worst-case conditions. On the other hand, being overly conservative will result in operating too far down scale for optimum accuracy.

7.1.6.4 Output Voltage or Current Requirements

Current output transducers are usually the best choice because of the reduced sensitivity to load resistance changes. Read-out at multiple points and at a distance is possible without accuracy reduction within the maximum output load rating. Be sure that output current or voltage rating is compatible with the indicating, recording, or controlling device that it is driving.

7.1.6.5 Accuracy and Stability Requirements

Two or more accuracy classes are often available from the same manufacturer. There is no need to pay for 0.1% accuracy when 0.5% is adequate. Stability (versus temperature and time) may be more important than the accuracy rating.

7.1.6.6 Environmental Conditions

Be sure that the transducer temperature and humidity ratings are compatible with the existing environment. Also, be sure that the effects of environmental conditions on accuracy are taken into account.

7.2 Oscilloscopes

7.2.1 Description

Oscilloscopes display waveshapes or can be used to display two voltages in Cartesian coordinates. By switching or using display tubes with more than one electron source (gun or beam), several wave-shapes may be displayed simultaneously. Most modern oscilloscopes contain amplifiers accurate to a few percent within the frequency range specified for the instrument. The built-in time-base generators allow accurate measurement of intervals within the waveforms. The time-base display is capable of being started (triggered) by several means:

- 1) the signal being observed,
- 2) an external signal,
- 3) an internal pulse, or
- 4) in some cases, (1), (2), or (3) with uncalibrated time delay for viewing later portions of the waveform.

7.2.2 Basic Mechanisms

The oscilloscope basically consists of a cathode ray tube and its driving devices. The tube contains an electron-beam-producing device, accelerating anodes, anodes to deflect the beam, and a phosphorescent screen, which makes the instantaneous position of the beam visible. Various phosphors can be chosen to cause longer or shorter retention of the image, and to provide different colors.

7.2.2.1 Cathode Ray Tube Power Supply

The cathode ray tube requires several different voltages for its operation, the highest of which may be in thousands of volts. The electrons acquire most of the energy that they transfer to the phosphor from this accelerating voltage. All the voltages for the tube are dc except for the heater supply, which is usually ac at low voltage.

7.2.2.2 Amplifiers

The deflecting anodes are controlled by amplifiers, which take the input signals from low levels up to the hundreds of volts necessary to deflect the electron beam. The construction of the cathode ray tube and the bandwidth of these amplifiers determine the high-frequency response of the oscilloscope. The stability of these amplifiers determines the long-term accuracy of the oscilloscope. Normally, the amplifiers are classified as to function. Those amplifiers producing vertical deflection of the electron beam are referred to as vertical amplifiers. Their voltage gain determines the vertical sensitivity of the oscilloscope, which is usually given in voltage per centimeter of beam deflection produced. These amplifiers usually have calibrated gain settings for exact ratios of deflection to voltage and also variable attenuators for adjusting deflections to convenient but uncalibrated magnitudes. In the X-Y mode, both horizontal and vertical deflections are controlled by external voltage inputs.

7.2.2.3 Horizontal and Vertical Position Controls

In addition to the image-size adjustment available with the deflection sensitivity (amplifier gain), the beam may be positioned to different locations on the screen with horizontal and vertical position controls. These add steady bias voltages to the amplifiers and allow reference levels or times to be conveniently adjusted to marks on the screen or graticule. If present, the beam locator button can be used to set these voltages so that the beam produces a visible image.

7.2.2.4 Focus and Astigmatism Controls

The shape of the electron beam at the point where it reaches the screen is controlled by adjustable fields inside the tube. These are adjusted by front panel controls to obtain the sharpest image on the screen. These settings frequently interact with the “brightness” or “intensity” controls, so that if the brightness of the trace is increased, the focus adjustment should be checked. If both focus and astigmatism controls are present, each controls a different aspect of the beam shape and should be adjusted for the desired spot shape.

7.2.2.5 Time-Base

The time-base section of the oscilloscope moves the electron beam linearly to the right of the screen with time, so that the horizontal axis of the beam picture on the screen is directly related to elapsed time. This allows a time-changing voltage to be examined in detail for period and sequence. This time rate is adjustable, frequently in accurately calibrated form, and calibrated in seconds per centimeter.

7.2.2.6 Probes

The inputs to the amplifiers of high-frequency oscilloscopes are critical as to capacitance if the highest accuracy is to be obtained. Special probes with adjustable capacitance are available. Probes may also be obtained to attenuate the signal so that higher voltages may be read, or so that higher input impedance, with less current drawn from the circuit being measured, is obtained. Normal oscilloscope inputs currently will present input impedances of $10^6 \Omega$, with calibrated probes frequently elevating this to $10^7 \Omega$ at the expense of a factor of 10 in sensitivity. It should be noted, however, that during the years 1965–1975 a number of high-quality oscilloscopes were made that had lower input impedances than those quoted above. If current loading may be a problem in the measurement process, the input impedance specification should be carefully checked on older oscilloscopes.

7.2.2.7 Electromagnetic Deflection

When very large deflections are necessary with high brightness, electromagnetic deflection is occasionally employed, as in TV sets or video data terminals, which are related to oscilloscopes. These deflection coils are mounted external to the cathode ray tube and driven by current amplifiers. The inductance necessary for magnetic deflection reduces the frequency range of the oscilloscope to the tens of kilo-hertz, but deflections of 20–30 inches are possible, providing large displays.

7.2.2.8 “Z-Axis” Modulation

The image of the electron beam can be brightened or diminished by applying an external voltage to the element that controls beam current. This is known as z-axis modulation. Each oscilloscope will have a different procedure for this, but since all oscilloscopes turn the beam off between time scans, the feature is usually available.

7.2.3 Single Trace Oscilloscopes

The single trace oscilloscope has only one vertical deflection system, and only one voltage can be displayed in the y-coordinate, or vertical plane. The x-coordinate (horizontal) may be either another voltage, or a linear time display.

7.2.3.1 Amplifier Calibration

If the vertical sensitivity is not marked on the oscilloscope in volts per centimeter on the vertical sensitivity control or switch, an external calibration signal should be used if accurate peak-to-peak voltage ratings are to be made on the oscilloscope display. If a sine wave is used, the rms value as read on an accurate meter may be multiplied by 2.8 to obtain the peak-to-peak value and that value used to calibrate the oscilloscope display. If the vertical sensitivity controls are then not adjusted between the calibration reading and the unknown reading, the same scale factor will hold for both.

7.2.4 Multiple Trace (or Channel) Oscilloscopes

Multiple trace oscilloscopes allow several signals to be viewed simultaneously. A separate vertical amplifier is usually used for each trace. Three systems are in use for providing separate traces, one physical and two electronic.

7.2.4.1 Multiple Gun and Deflection Systems

In this system, the separate beams are supplied and deflected by individual electron gun systems within the cathode ray tube.

7.2.4.2 Switched Beam Systems (Chopped)

In these systems the connection to the vertical beam deflecting system is switched rapidly between the two input channels while the horizontal deflection is taking place. If the switching is rapid enough, the traces appear to be continuous. This method has the advantage of allowing the time relations between two waveforms to be viewed directly at almost identical time intervals.

7.2.4.3 Alternating Trace Systems

In alternating trace systems, a complete horizontal traverse of the beam is allowed before any other waveforms are switched to the vertical deflection. After all channels have been viewed on single sweeps, the first one is displayed again. The phosphor of the screen usually retains enough luminosity to hold the system image between sweep cycles. With an alternating trace system no part of the waveform is lost during a horizontal trace interval, but the viewed waveforms do not occur in the same time frame. Since both the switched and alternating trace systems involve electronic switching, they are frequently both available on a single instrument on a switch-selectable basis. As many as eight traces may be available by using switching systems and multiple guns.

7.2.5 Portable Oscilloscopes

A few oscilloscopes are available that can be operated from internal rechargeable batteries, or from external low-voltage supplies that could be obtained from batteries. Due to the large number of amplifiers and the numerous voltage levels necessary to run the cathode ray tube, battery life is relatively limited, and display size is fairly small compared to line-powered oscilloscopes. Battery-powered oscilloscopes can be operated at any reference voltage level for measuring small voltage differences at high potentials above ground. Measuring small voltage differences at high potentials above ground, however, involves the chassis and controls being at risk of assuming any of the potentials being measured in the case of insulation breakdown. The oscilloscope specifications should be carefully consulted, and the instrument isolated from personnel during the measurement. De-energizing the circuit being measured is a necessary precaution during connection, disconnection, or adjustment of the oscilloscope. See also 7.2.10.

7.2.6 Sampling Oscilloscopes

For measuring very high-frequency repetitive waveforms, switching techniques can be used to develop a picture of a waveform by taking successive samples on many cycles of a wave to be measured. Such oscilloscopes can be used to make measurements several octaves above the point where linearly amplifying oscilloscopes become economically

impractical. Since the waveform is displayed as successive samples, events that change from cycle to cycle show up as noise in the display.

7.2.7 Memory Oscilloscopes (Storage Oscilloscopes)

It is frequently desirable to take a single electrical event and retain an oscilloscope display of its entirety. Memory oscilloscopes are capable of retaining the image produced by a single sweep for a selectable amount of time. This memory may be obtained directly by electrostatic means within the cathode ray tube, where the phosphor is “refreshed” by a separately controllable electron source so that the picture, once obtained, is self-perpetuating. The memory may also be obtained by rapid digitization of the waveform segments and digital storage of the data as in a computer, with access available as necessary during the scan of the beam across the tube. This form of storage also allows some signal processing, and it becomes increasingly difficult to distinguish computer from oscilloscope as the number of operations performed on the waveshapes increases. Delay line schemes are also occasionally used to form a storage system, but the length of line involved in storing even a microsecond’s worth of waveform is physically large, so this method is restricted to short time intervals.

7.2.8 Time Measurements, Triggering

The speed at which the beam of electrons sweeps horizontally across the face of the oscilloscope is precisely controllable, and so oscilloscopes can measure waveform rates and times between waveform events with a high degree of precision. Photographs of oscilloscope displays can be physically measured and/or used as a permanent record of such time relationships. Phase relations can be determined if a two-gun (or x-y display) oscilloscope is used. Frequency can be determined as the reciprocal of the measured time per cycle. In order that time be measured accurately, not only must the sweep be accurate, but the waveform must start at the same part of the cycle on each repetition of the trace. For this reason, several controls are provided to “trigger” or begin the sweep. The sweep is usually blanked, or turned off, when not being triggered, so a lack of display on a triggered-sweep oscilloscope usually indicates an insufficient input. The various types of triggering modes available are Auto, Normal, 60 Hz, TV, and Delayed Automatic Trigger mode.

7.2.8.1 Automatic Triggering

Automatic triggering initiates the sweep upon the detection of a non-zero signal in the selected input channel. (The channel to be used in the triggering process is usually switch-selected in multitrace oscilloscopes.) This is the mode most likely to produce a trace, but the pattern is not well controlled by the input signal and may appear to move on the screen or jump from cycle to cycle.

7.2.8.2 Normal Triggering

Normal triggering starts the sweep only when the input voltage reaches a level that is predetermined by the “trigger level” control on the oscilloscope control panel. This is usually marked “+” and “-” to indicate which polarity is to be used to trigger the sweep. Some trigger circuits further provide the option of selecting rising or falling voltages in addition to the magnitude itself.

7.2.8.3 60 Hz Trigger

This trigger selection starts the sweep from the 60 Hz line signal. Waveforms that are produced by line-related phenomena at 60 Hz, or multiples thereof, will be stationary when displayed with this triggering mode.

7.2.8.4 TV Trigger

Waveforms in a television set are all tied to the 30 Hz vertical frame rate and the 15 750 Hz horizontal line rate. Oscilloscopes used for television service work usually have a trigger position for one of these rates to allow the viewing of a stationary waveform.

7.2.8.5 Delayed Trigger

In viewing events that occur in extremely short time intervals, it is possible to look at a portion of a repetitive wave that occurs at a predetermined delay after the cycle begins. The ordinary trigger is set in the usual fashion, and then a separate calibrated time delay used to initiate a second sweep (which may be at a much higher rate) after the first sweep has begun.

Some delayed sweeps will show the portion of the trace selected for magnification as a brighter segment on one sweep, and then show the delayed (and possibly magnified) segment below it. The circuits for accomplishing this, and the control labels, vary considerably from manufacturer to manufacturer. Careful reference to the individual instruction book is usually necessary for optimum usage of this feature.

7.2.9 Bandwidth

Oscilloscopes are usually rated either in terms of the high-frequency sine wave that produces 70% of the low-frequency deflection for the same voltage (-3 dB point), or in terms of the time that it takes the beam display to rise from 10–90% of its final value for a perfect square wave input. Sometimes both are given, since the relationship between the two is partly a function of the number of amplifier stages in the channel being considered. A great deal of digital circuitry employing bipolar transistors currently produces waveforms with rise times of 10^{-8} s and less. Accurate evaluation of these rise times requires an oscilloscope of faster rise time, or bandwidth in the 100 MHz range. CMOS logic and analog communications circuits can generally be evaluated with far less bandwidth.

7.2.10 Precautions

If the differential input connection is not used, one of the terminals of the input connection to the oscilloscope is usually connected to the power line ground (except for battery-powered oscilloscopes—see 7.2.5). This requires some caution in making circuit connections if power line values are being measured. Devices have recently been developed for use with the oscilloscope that allow isolation by optically coupled devices so that a grounded oscilloscope may be used with potentials to several thousand volts.

7.3 Analog Recording Meters and Devices

7.3.1 Description

Analog recorders offer a means for presenting static or slowly changing phenomena in a permanent record form that may be analyzed or used for demonstration and presentation. These recorders exist in many forms, such as intermittent write, direct continuous write via pen or stylus, and high-speed light beam writing oscillographs. Recorder charts also exist in a wide variety of forms, such as circular, endless loop, single-channel strip, and multiple-channel strip charts. These charts can have either linear or logarithmic graduations on them, scaled or time graduations, or levels of the phenomenon that they are designed to record. Most modern analog recorders have electronics associated with them to amplify, filter, attenuate, or otherwise condition the electrical input that they are recording. Certain new recorders are actually small-scale data acquisition systems that sample dynamic data, store it in digital memory, and convert it back to an analog voltage to be displayed on a chart in a scaled time reference.

7.3.2 Analog Signal Processor

This is an important part of the recorder since it converts the input signal to one that is within the basic recorder's range and sensitivity. Often, the input signal processor is as simple as an inductive or resistive voltage divider that reduces the input signal to a level tolerated by d'Arsonval or taut band meter movement. Many modern electronic charge recorders utilize sophisticated electronics to amplify and condition the input signal. These electronics can be single stages of buffer amplifiers or sophisticated variable gain, differential amplifier stages followed by active filters with selectable cutoff frequencies. Newer multiple-purpose chart recorders are actually small-scale data acquisition systems. Differential amplifiers precede analog-to-digital converters, and sample and hold amplifiers form the signal

conditioning front end of the actual recorder electronics. As need for higher frequency response requires higher writing speeds, attention to recording problems, such as noise, common-mode rejection, and anti-aliasing filtering is required. Each of these problems can be reduced by more sophisticated electronics, but the user should decide if his application warrants the greater complexity and higher original cost.

7.3.3 Basic Recorder Mechanisms

Two basic mechanisms make up any recorder or recorder system, namely the chart drive and the means for writing on the chart. Chart drives can be as simple as a spring-driven motor which drives the chart via gears, chains, or belts for low-power, remote recording, or as complex as digital stepping motors which are driven by pulses derived from a crystal-controlled oscillator. Drives vary from single-speed circular motion systems, which can be gear-driven by synchronous motors, to ones that offer a selection of speeds that are controlled via microprocessor and vary from 1 mm/h to 100 mm/s in 1. mm increments. Most drives used presently are stepper motors with from 5 to 15 pushbutton-selected speeds for general purpose chart recorders. Most chart recorders now use a knurled driven axle that presses the chart paper against rubber on an idler wheel or shaft and pulls the paper across a platen upon which the pen mechanism writes.

Writing mechanisms vary among chart recorders similarly to drive mechanisms. The simplest writing mechanism consists of a small hammer mechanism that is on the end of an arm connected to a d'Arsonval meter movement. Approximately once every two seconds a bar presses the arm onto a special waxed paper making a small mark on the chart paper by displacing the wax film which is on top of black paper. Continuous, real time charting requires a pen in contact with the chart continuously, and manufacturers have tried many methods to obtain a reliable pen and ink writing system. Typically, pen and ink writing methods utilize very low mass pen points on the end of rigid arms connected to galvanometers. There are many inherent problems with this type of writing system. Among these are the obvious clogging and blotting of the pens and very definite dynamic range problems making a tradeoff necessary between writing speed and throwing ink. To alleviate these problems, several manufacturers have developed thermal writing stylii which provide greater reliability, no mess, and long life when used with thermal paper. Typically, the heat applied to the stylus is set via a rheostat on the recorder front panel and is varied by a feedback-control system connected to the chart speed selector mechanism. These systems are typically superior to ink writing systems and allow for much greater real time writing speeds, which translates into a greater system frequency response. A few manufacturers have taken this technology one step further and have eliminated the moving stylus altogether. In the place of the stylus, they have positioned one or more dot addressable thermal writing heads over which the paper travels. By doing this and utilizing microprocessor technology, a whole new class of chart recorders has been developed. These are discussed in more detail in 7.3.8.

7.3.4 Single-Function Chart Recorders

Recorders that have a single speed and input range, or are meant for permanent mounting or for monitoring a single phenomenon, fall into this category. The classic example of this type of recorder is the single-channel, inexpensive, long-term recorder, which uses the periodic hammer writing mechanism as described in 7.3.3. Another example is the common circular chart recorder used to measure temperature, barometric pressure, or any other slowly changing phenomenon. Many of these recorders are completely self-contained and do not require external power or connection to a transducer. Often they have an internal gear-driven clock works that will give them a 24-hour, 1-week, or 1-month full-scale record rate. An advantage of the circular chart recorder is that it inherently displays its entire full-scale data and time in an easy-to-read format. Other examples are simple 1, 5, or 10 V or 1, 10, or 50 mA full-scale hammer-type single-channel chart recorders, which are used to monitor remote transducers. All of the above are commonly used on the industrial power environment due to their simplicity, economy, and ruggedness.

7.3.5 Single- and Multiple-Channel Chart Recorders

Recorders that are rack-mounted or portable having either a single pen or multiple pens or stylii, and having from two to five chart speeds selectable from the front panel, constitute this category. These recorders constitute a limited multipurpose category and have been used in the industry for many years. Often they may have two pens that are mounted on overlapping arms so that each pen can utilize the full chart width. In this type, two different colors of ink

or two different snap-in pens are used. Often in multiple-point or multiple-channel recorders, the pen travel is limited to 40 or 50 mm so that occurrences on different channels may be observed and compared with respect to time. Often this type of recorder is used to monitor multiple levels of pressure or temperature in a boiler or cooling tower. These recorders usually have fixed full-scale input limits of 1 V or 1 mA and chart speeds of 1–10 mm/min.

7.3.6 Portable and Diagnostic Chart Recorders

Recorders that are relatively compact have from two to eight channels, have variable signal conditioning controls, and have multiple chart speeds. These are common as measurement or diagnostic tools of the industry. These recorders are true self-contained measurement systems with internal electronics that allow the user to select channel sensitivities and chart speeds to suit the needs of the measurement. Common configurations include individual channel amplifiers that switch selectable sensitivities of 1 mV to 5 V/mm in a 1-2-5 sequence, and selectable chart speeds from 1 mm/min to 1 mm/s also in a 1-2-5 sequence. The chart speed will be constant for all channels, but typical design allows individual voltage sensitivity settings for each channel. Often these recorders will have a pen or stylus on the side of the chart that marks the chart once per second to give a time relationship relative to some chart start time. Older versions of these recorders use take-up rollers to collect the chart that has been written on, but newer versions are utilizing fan-fold charts that stack up external to the recorder and are much easier to read and refer to events recorded much before the last event recorded.

Charts for these recorders are readily available in a variety of channel width formats. Single- or two-channel recording charts often are 200 or 100 mm wide, respectively, and four-, six-, and eight-channel charts usually have 40 or 50 mm-wide channels. Premarked charts in engineering units are available from the recorder manufacturers or specialized chart paper manufacturers.

7.3.7 High-Speed Oscillographic Recorders

These recorders form a special category by means of their ability to capture and record relatively high-speed periodic and transient signals. Typically, these recorders have from one to eight channels with either fixed sensitivity or variable sensitivity signal conditioning electronics built into the recorder. Chart speeds range from 10 to 100 in/s, and because of these speeds, no paper take-up rollers are used. Also, because of the speeds at which these recorders are able to write, no mechanical writing mechanism is utilized. Instead, these recorders utilize a light beam reflected off a small, low-mass mirror mounted on a driven galvanometer to write on photo-sensitive paper and are commonly called *light beam oscillographs*. Signals up to tens of kilohertz can be recorded accurately with these devices, and records of transient voltage in the hundreds-of-microseconds range may be captured.

Typical applications of these recorders include system testing and energization of new electrical substations. They are very useful for locating and diagnosing fault conditions or other problems caused by circuit-breaker energization and switching. Often these devices are used in parallel with transient digitizers so that results of testing can be examined immediately on-site during testing and compared to reduced data later for more detailed signal analysis. Advances in microprocessor technology and the lowering cost of semiconductor memory may cause the obsolescence of these devices. New developments in recorders are discussed in 7.3.8, which follows.

7.3.8 Multifunction and Modern Chart Recorders

Recorders that do more than just record an input signal are detailed below. With the advent of microprocessor control and stored programs, the analog chart recorder has evolved into an intelligent measurement and recording device. Recorders now coming to the industrial marketplace are actually small-scale data acquisition systems that are carefully engineered to alleviate most of the shortcomings of the many recorder designs of the past. Many of the capabilities of this new generation of recorder are outlined as follows:

- 1) Direct writing speed to several hundred hertz
- 2) Clean, nonsmudge, easy-to-read, fan-fold thermal paper
- 3) Easily selected and set recording parameters, such as chart speed, input gain and sensitivity, trigger points, and run times

- 4) Time and other pertinent data logging on the chart along with the data as it is being recorded
- 5) Input level sensing and triggering capabilities allowing both pre- and post-trigger recording of phenomena
- 6) Time-compression recording allowing the user to display on the chart frequencies well beyond normal recorder capabilities
- 7) Multiple choices of number of channels used, channel width, overlapping or non-overlapping channels, and waveform annotation.

These capabilities add a new dimension to “analog” chart recording, giving the technician or engineer using the instrument much greater accuracy and flexibility for his analysis of the data collected during testing or troubleshooting. Recording and display accuracies of better than 1% now are possible where, in the past, analog recording devices were little more than tools that allowed display of slowly changing events.

7.3.9 Other Analog Recording Devices

Strip chart devices are the most prevalent analog recording devices, but there are others that are less commonly used. Analog instrumentation tape recorders are occasionally needed for remote, unattended transducer monitoring. These recorders typically have several adjustment and calibration features that allow them to be more accurate than chart recorders, but these features also make them more difficult to use. Multispeed instrumentation tape recorders also have capabilities of recording much higher frequencies, typically to 40 kHz, than chart recorders. These recorders typically use 5- or 7-inch reels of high quality $\frac{1}{4}$ -inch recording tape, although $\frac{1}{2}$ -inch and 1-inch tape widths are not uncommon. Signals can be recorded using both AM and FM techniques. These devices have characteristics that have both advantages and disadvantages. They may be completely portable and battery-powered to enable use in remote locations, but by this very virtue, one cannot evaluate the data taken until it is played back into other instruments such as oscilloscopes or chart recorders.

Another instrument used for very limited signal recording is the memory voltmeter. This meter can measure and track a single input voltage and hold the greatest or peak value of this voltage that occurred during the measurement period. The meter has fairly slow response, several Hertz maximum, but does serve a purpose if peak voltage monitoring of a process or test parameter is needed.

Other devices used for recording analog phenomena include storage oscilloscopes with or without the use of camera, video recorders, and transient digitizers of various types. Digital techniques have been utilized to enable measurement of high-speed, short-duration analog signals.

Most analog recording instruments and techniques offer low accuracy, 1–3% typically, but in turn offer very high information content of the signal being measured. Advantages include continuous output of data, long-term monitoring capabilities, direct display of the phenomena being measured, and relatively easy comparison and analysis of data taken. Disadvantages include limited frequency response, fairly expensive recording media (paper charts), and typically fairly high maintenance requirements. Many of the disadvantages are being alleviated by the incorporation of digital techniques into analog instruments, making these important diagnostic and measurement instruments.

7.4 Power Supplies

7.4.1 Description

Electrical testing of equipment (prototype, acceptance test, quality control, etc.) requires sources of power with voltages and frequencies different from what the available local sources can deliver.

7.4.2 Alternating Current Sources

7.4.2.1 Variable Auto Transformers and Voltage Regulators

They are built as single or polyphase units which allow the variation of the amplitude of the output voltage. The adjustment is made manually or by means of servomotors. See Fig 7-1.

7.4.2.2 Solid-State Converters

In many applications the ac load can be supplied with nonsinusoidal voltage. In such situations it is more economical to use thyristorized converters (silicon-controlled rectifiers, triacs, or gate-turn-off rectifiers (GTOs) than variable autotransformers or voltage regulators. The main advantages of solid-state units are small volume and fast response time ($1/2$ cycle). The main disadvantage is the distortion of the line current. See Fig 7-2.

7.4.2.3 Inverters

An inverter is a device supplied from a dc source and, through sequential switching, the dc voltage is transformed to ac. By varying the inverter switching frequency, it is possible to vary the frequency of the ac output. By varying the amplitude of the input dc source, the amplitude of the ac output can also be varied. See Fig 7-3.

The dc source can be a battery or a rectifier.

7.4.3 DC Power Supplies

These devices convert ac to dc. Power supplies can be designed to provide constant voltage, CV, or constant current, CC. Some general purpose laboratory units can be operated in either CV or CC mode as shown in Fig 7-4.

The ability of the supply to maintain CV or CC, output is specified by its load regulation. This is the actual change in the "constant" output from no-load to full-load.

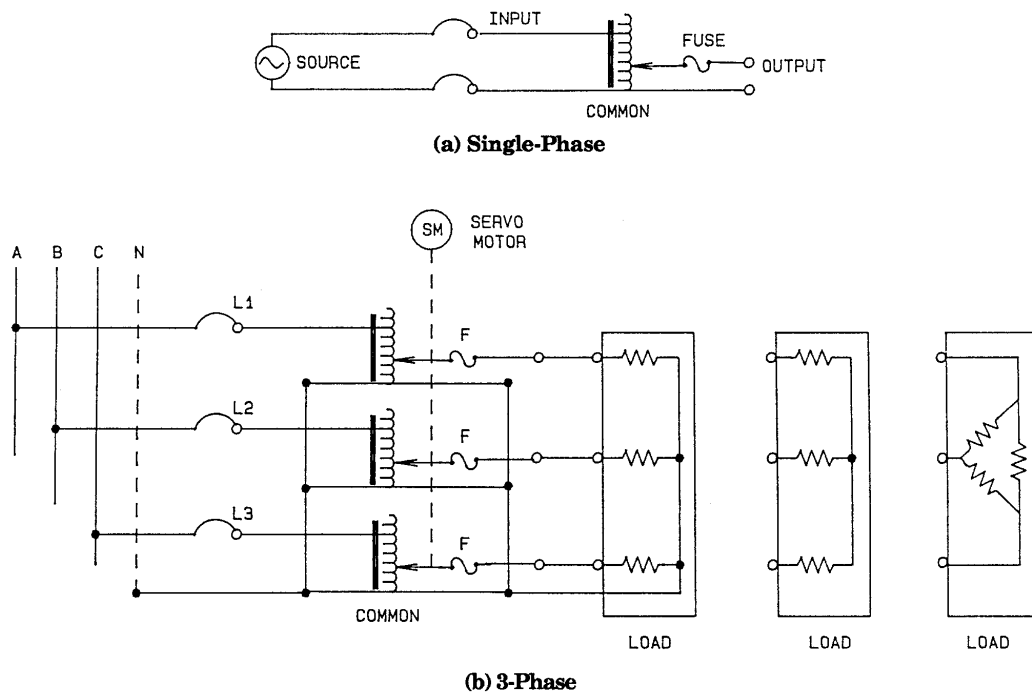
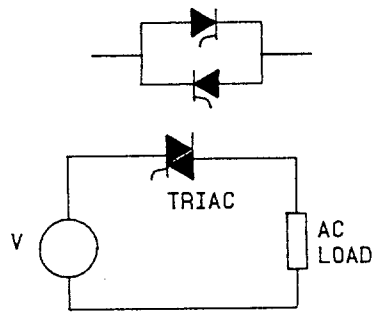
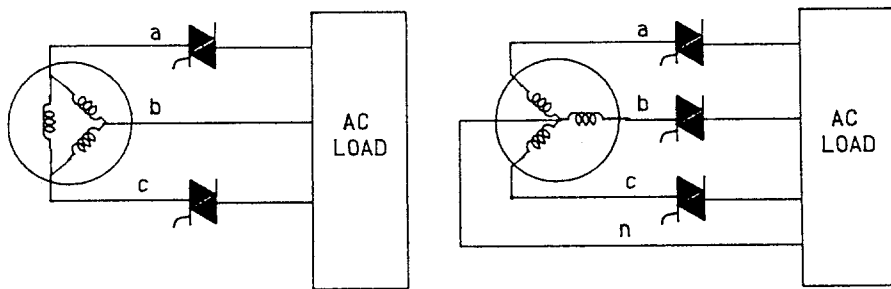

Figure 7-1—Variable Autotransformer Connections



(a) Single-Phase



(b) 3-Phase

Figure 7-2—AC-Controlled Leads by Means of Solid-State Converters

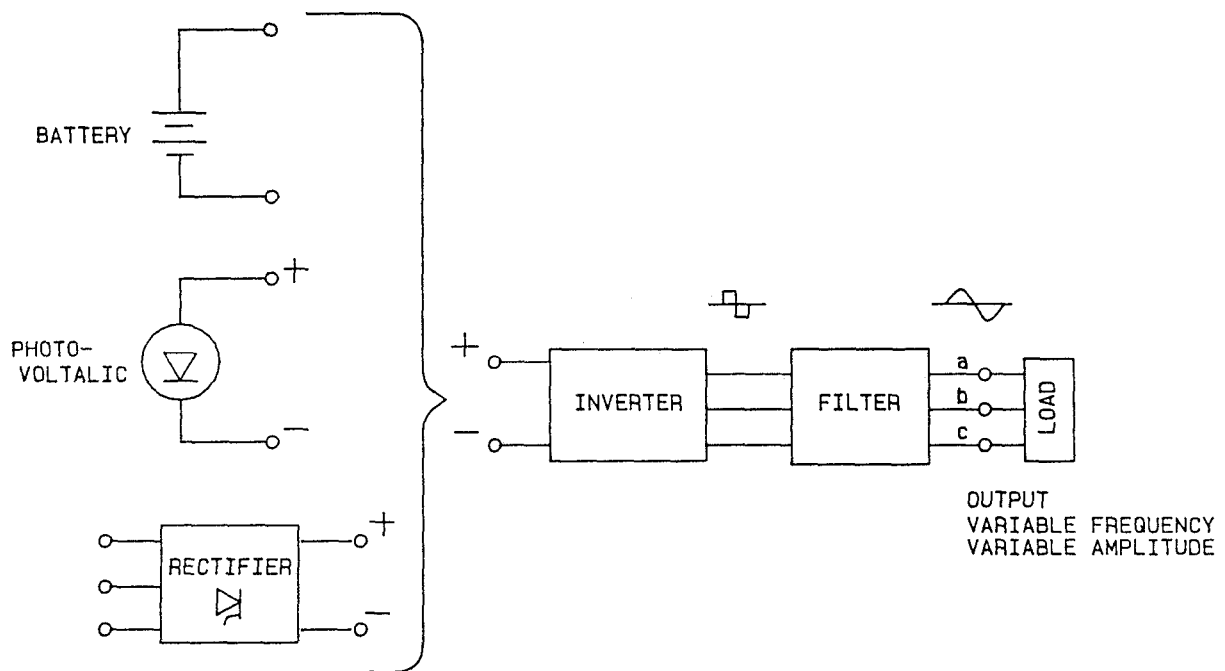
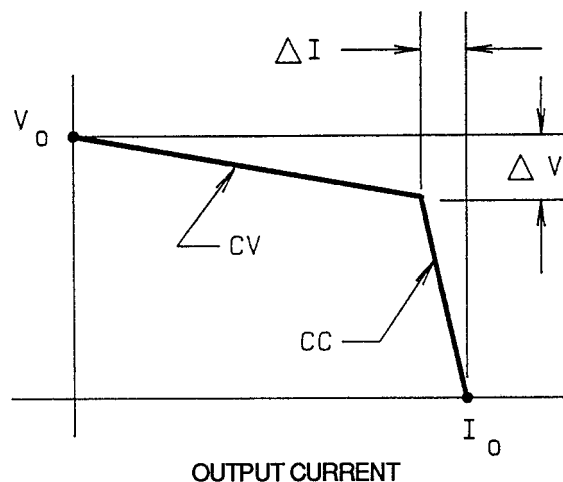

Figure 7-3—Block Diagram Showing the Main Components of an AC Supply Using Inverter



Voltage regulation, $R_V = (\Delta V/V)100$ (%)
 Current regulation, $R_I = (\Delta I/I)100$ (%)

Figure 7-4—Voltage-Current Output Characteristic of a DC Voltage Supply

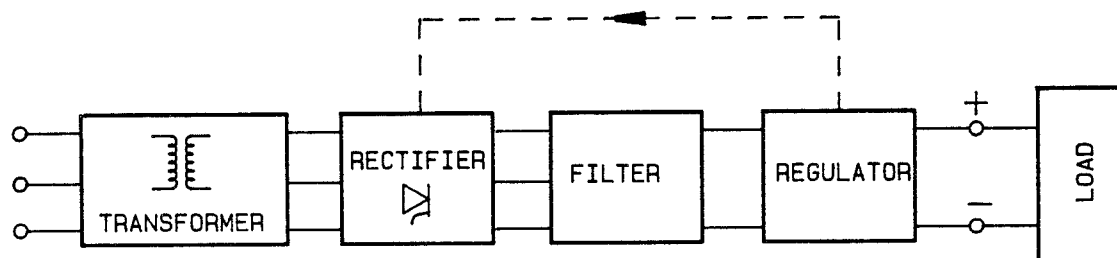

Figure 7-5—Main Components in a DC Supply

A typical dc supply is described in Fig 7-5 where the incoming ac voltage is stepped up or down by a transformer. The secondary voltage will feed a rectifier. The rectified wave is fed to a filter that smooths out the ripple in the rectified waveform. With the help of the regulator, the supply output voltage is maintained constant over the desired range. When dc voltage variations are nonconsequential there is no need for a regulated power supply.

7.4.3.1 Definitions

7.4.3.1.1 DC Output: Describes the range of dc voltages or currents available from a power supply

7.4.3.1.2 AC Input: Describes the characteristics of the ac voltage required to drive the power supply (115 V ac \pm 10%, 50–60 Hz)

7.4.3.1.3 Load Regulation: The change in the dc output resulting from a change in the load over its operating range. Typical values are 0.001–1%

7.4.3.1.4 Line Regulation: The change in the dc output resulting from a change in the input line voltage from its lowest to its highest specified value.

7.4.3.1.5 Ripple: Describes the rms value of the ac component that remains unfiltered and superimposed on the dc output.

7.4.3.2 Connections

Typically, the voltage between (+) and (–) terminals is floating. If a load is connected between (+) and ground terminal alone, the output voltage of this connection will be zero. To supply a voltage output relative to the ground, the ground terminal must be connected separately to either the (+) or (–). Some supplies have the (+) or (–) terminals permanently grounded. See Fig 7-6

7.4.3.3 Guidelines

Use quality connections, such as spade lugs, that can be slipped onto the power supply binding post nut and then tightly clamped down. Causal, clip-lead connection will lead to large contact resistance.

When more than one load is connected in parallel to a power supply, Fig 7-7, connect each load with a separate set of leads. In this way, variations of the current through a single load will not affect the voltage applied to other loads.

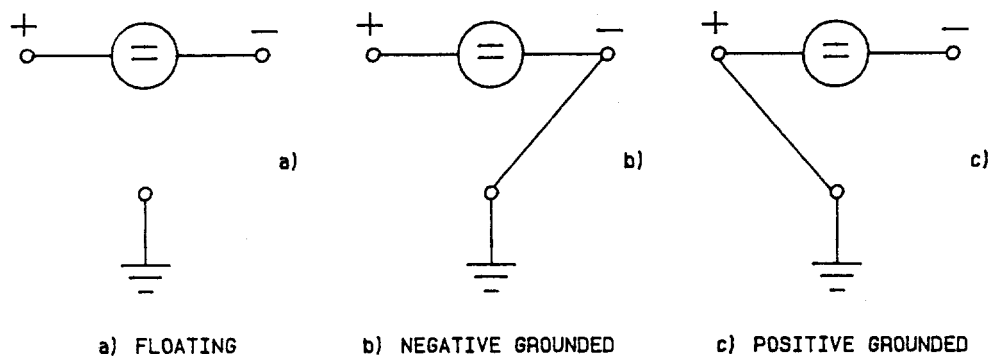

Figure 7-6—Ground Connections

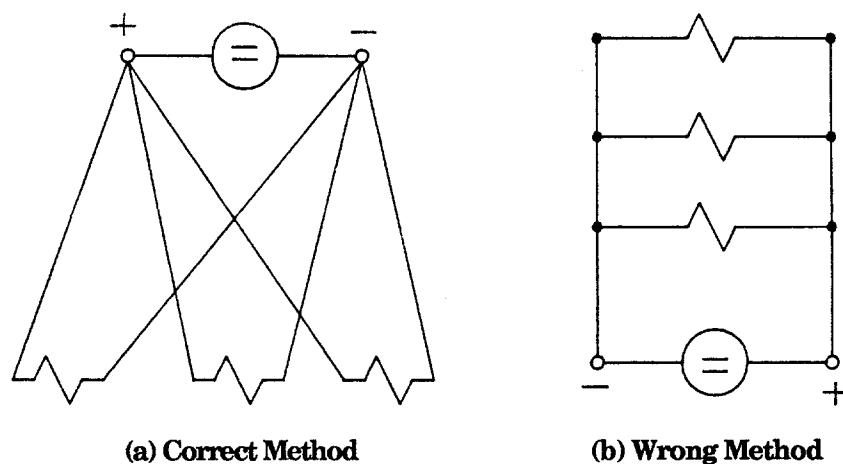

Figure 7-7—Connecting Multiple Loads to the Same Source

7.5 Bibliography

[1] ANSI/IEEE Std 460-1988, IEEE Standard for Electrical Measuring Transducer for Converting AC Electrical Quantities into DC Electrical Quantities.¹²

[2] ISA S82.01-1988, Safety Standard for Electrical and Electronic Test, Measuring, Controlling, and Related Equipment—General Requirements.¹³

[3] ISA S82.02-1988, Safety Standard for Electrical and Electronic Test, Measuring, Controlling, and Related Equipment—Electrical and Electronic Test and Measuring Equipment.

[4] ISA S82.03-1988, Safety Standard for Electrical and Electronic Test, Measuring, Controlling, and Related Equipment—Electrical and Electronic Process Measurement and Control Equipment.

¹² ANSI/IEEE publications are available from the Institute of Electrical and Electronics Engineers, Service Center, 445 Hoes Lane, Piscataway, NJ 08855-1331, or from the Sales Department, American National Standards Institute, 1430 Broadway, New York, NY 10018.

¹³ ISA publications are available from the Instrument Society of America, Standards Department, 67 Alexandria Drive, P.O. Box 12277, Research Triangle Park, NC 27709.

8. Chapter 8—New Technology

8.1 Computer-based Techniques

8.1.1 Description

Converting physical and electrical phenomena into a form that may be interpreted, analyzed, and stored in digital computers and their peripheral devices requires modern, electronic, digital techniques. These techniques are defined in terms that are often unrelated to the measurement per se, but describe the digital phenomena or means to perform the measurement.

Computer-based measurements inherently involve four steps: analog signal processing; analog-to-digital conversion; digital processing; and digital storage. Each of these steps may be performed in a variety of ways and are defined in terms of ultimate accuracy, applicable frequency range of measurement, processing rate, and capacity and rate of storage.

8.1.2 Analog Signal Processing

Involves the electronic measurement of the phenomenon to be stored, displayed, or analyzed by the computer.

8.1.2.1 Anti-Aliasing Filter

All analog signals to be measured should be filtered by some means to ensure accurate measurement. This filtering may be inherent, as in the case of integrating digital methods, or be included in the electronics, as in the case of transducers which output a dc signal proportional to the phenomenon being transduced. In most cases, this filtering should be specified and is a function of the measurement accuracy required and frequency content of any possible electrical noise sources—usually 60 Hz. Knowledge of the time variance of the phenomenon to be measured is also necessary. This can be thought of as maximum rate-of-change of output signal level.

8.1.2.2 Nyquist Criterion

Also known as the Sampling Theorem, the Nyquist Criterion states that in order to reproduce a time-varying signal without distortion caused by aliasing, the signal must be bandwidth-limited, and the sample rate must be at least twice the frequency of bandwidth limitation, f_c . This criterion is fundamental to any sampled data system.

8.1.2.3 Filter Rolloff

A specification of the effectiveness or sharpness of any particular electronic filter. Usually specified in decibels per octave or decibels per decade, referring to voltage ratios of input to output where $\text{dB} = 20 \log_{10}(V_{\text{out}}/V_{\text{in}})$. A rolloff of 6 dB per octave mathematically expresses the attenuation slope that one pole (R-C element combination) of filtering will supply per doubling of the frequency from a reference frequency, f_c , usually the corner frequency or 3 dB point of the filter. A rolloff of 6 dB per octave is identical to a rolloff of 20 dB per decade. Additional poles each contribute an additional 6 dB per octave rolloff added to the first or subsequent poles.

8.1.2.4 Filter Types

May fall into several categories, active or passive, capacitive or inductive, discrete or integrated circuit. Most common filtering used in data acquisition systems is an active (operational amplifier realized) low pass filter with two or more poles, and a Butterworth or maximally flat response. Terms such as Constant K, M Derived, Couer, Chebychev, Bi-Quadratic, Constant Ripple, etc., refer to the characteristics of the particular filter or how it is designed. Terms such as active, passive, and switched capacitor refer to how the filter is realized electronically.

Passive filters typically require more and physically larger components to realize a given filter function than active filters. Active filters are most commonly used in the audio frequency spectrum for data acquisition systems. Passive filters are more commonly used for work in the radio frequency spectrum. Switched capacitor filters are a relatively modern method of realizing active analog filters by combining digital techniques and easily replicated integrated circuits.

8.1.3 Sample Data Systems

All digital data acquisition systems involve a sampling and holding of analog signals at some rate and for a finite period of time. The sample rate must fulfill the Nyquist Criterion (see 8.1.2.2), but there is no specific criteria for sample width. Ideally, sample width is of as narrow or short duration as possible somewhat analogous to differential calculus requiring X to approach an infinitely small increment. This sampling of the analog signal or signals is performed by one or more sample-and-hold circuits, which operate under computer control. These circuits typically utilize high-speed operational amplifiers, electronic switches, and high-quality capacitors to sample the voltage on the analog signal, that is, to measure it over a very small time period and store that value on a low-leakage capacitor so that it may be digitized. These samplings often consist of 25 μ s or shorter measurements of the analog signal. Samplings may occur serially or in parallel, depending on the nature of the measurement. Multi-channel data that is to be correlated in time needs to be sampled at exactly the same time and, therefore, must be sampled in parallel. Data that is not time-critical may be sampled serially, or one channel after another. Serial sampling still is able to be done rapidly with as many as 64 channels sampled in as little as one millisecond being common.

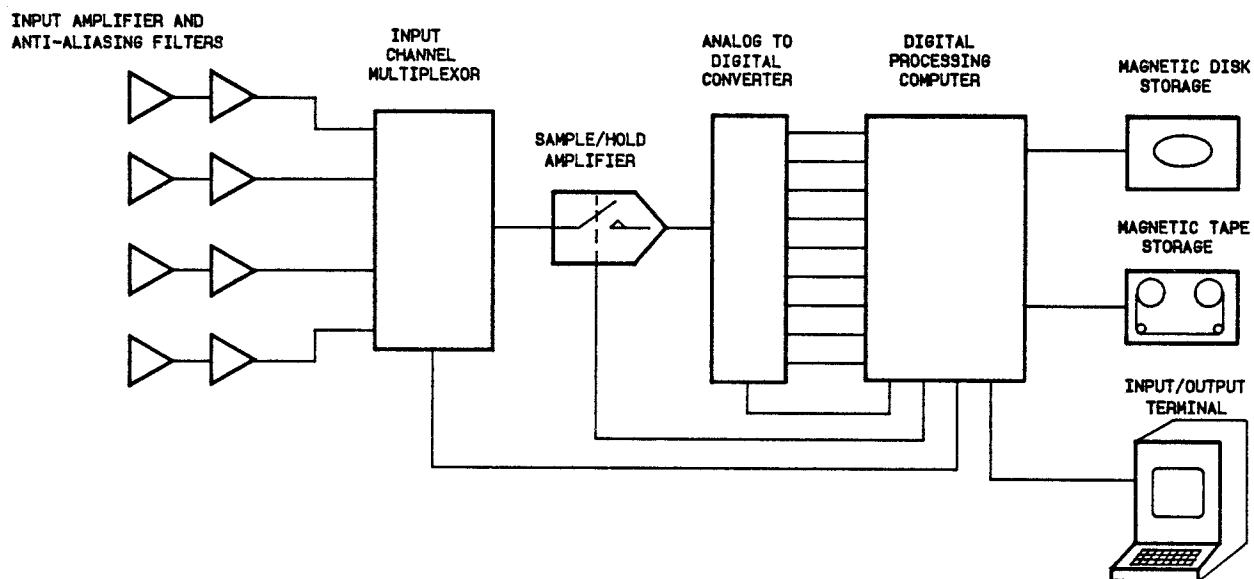

Figure 8-1—Typical Data Acquisition System Configuration

8.1.3.1 Analog-to-Digital Conversion

Involves digitizing or converting a real-time signal of voltage or current into a digital pulse stream. Various techniques and methods are used for analog-to-digital (A to D) conversion. The most common with their respective characteristics are summarized as follows:

Single Slope or Ramp: Obsolete, illustrative of methods; inaccurate.

Dual Slope: Accurate but slow; inherently monotonic and averaging; used where signal integration is required; high noise rejection; only method that does not need a separate sample-and-hold circuit.

Successive Approximation: Fast and accurate method; requires sample-and-hold circuit; may not be monotonic; less accurate than *dual slope* and can inject noise onto low-level signals. May be more easily and economically used in multi-channel applications, such as data acquisition systems.

Flash Converters: Very high-speed, parallel conversion; less accurate than other methods but fastest known method for A to D.

Charge Balancing: Not often used; sometimes called quantized feedback; not as fast as *successive approximation*; lends itself to use with microcomputer.

Accuracies of A to D converters are expressed in bits or powers of two. An 8-bit converter can resolve to ± 1 bit in 2^8 or 256 parts. This gives a resolution of $\pm 1/2\%$ and a best possible accuracy of $\pm 1\%$ due to least significant bit (LSB) uncertainty. A to D converters with 14 and 16 bits are readily available. Combinations of 12 bits accuracy and 25 kHz signal throughput are readily available commercially.

8.1.4 Digital Storage

Data acquisition systems or subsystems typically present their data output in a parallel format to the computer that controls their activity. This data may be simply stored, manipulated, time-tagged, converted into engineering units, or used in some calculation or process by the computer. The type of end use dictates the type of storage in the computer, RAM (random access memory), or RAM-Disk for short-term storage; floppy disk for long-term storage with possible future use; hard disk for long-term large quantity of data storage; or magnetic tape for high-volume, long-term data storage. For small-scale data acquisition or remote data logging, programmable read-only memories or magnetic bubble memories are sometimes used and then read by some central computer and stored on another medium. Digital and analog cassette tapes are utilized by various data loggers, but again require a reader for data reduction and analysis at some central site with a computer.

8.1.4.1 Magnetic Tape

Used in many forms, such as digital and analog cassettes, $1/4$ -inch cartridges, large reels of $1/2$ -inch tape with 7- or 9-track format with various record densities and formats. Reels of $1/2$ -inch tape are used mainly with large computers or multi-channel, high-speed data acquisition systems. There are many recording formats in use, but the most common are non-return to zero (NRZ), and non-return to zero inverting (NRZI). Different computer manufacturers use different recording formats for digital storage, but IBM 9-track is among the most common.

8.1.4.2 Magnetic Disks

Used in two basic forms: hard and soft, or floppy diskettes. Hard disks have the greatest recording or data density and may be used in "packs" of more than one disk per drive to achieve data capacities of hundreds of megabytes. Small-scale desktop computers may utilize single hard disks with 10, 20, or more megabytes of storage per drive.

Hard disks for digital storage exist in a variety of physical sizes and recording densities. These range from 14-inch diameter single- and double-sided disks used by mainframe and large minicomputers to 3-inch diameter disks mounted on printed circuit boards and installed inside personal desktop computers. Recording formats differ between manufacturers but are basically similar. Hard disks and disk drives are more fragile and sensitive to environmental conditions than floppy diskettes. This sensitivity increases their cost and limits their use somewhat, but in applications where large amounts of data are to be stored or manipulated, they are extremely useful and cost-effective.

Floppy disks are made in three sizes: 8 inch, $5\frac{1}{4}$ inch, and $3\frac{1}{2}$ inch, with the $5\frac{1}{4}$ inch being most prevalent at this time. Several different data and recording formats exist for all sizes of floppy disks. Examples are single-sided, single-density recording (35 tracks per inch); single- and/or double-sided, double-density (48 tracks per inch); quad-density; and others. No standards exist at this time, and machine-to-machine incompatibilities are common. De facto "standards" exist as far as common formats are concerned, and the most common are CPM and IBM. Basic recording methods are similar between most, if not all, manufacturers and consist of recording digital data onto "sectors" of

“tracks” on a thin circular plastic disk with various formulations of ferromagnetic oxides on its surface. The tracks are concentric bands of fixed width that are divided into a varying number of sectors or arcs of fixed length that contain a fixed number of bytes of data, check-sums, synchronizing codes, and recording gaps. The thin disk is encased in a square carrier that protects and lubricates the disk which is spun inside the carrier via a central hole that fits over the disk drive’s hub. The carriers are similar for disks of the same diameter, but vary between differing diameters of disks with the 3¹/₂-inch disk having the thickest and heaviest carrier. The 3¹/₂-inch disk also is the latest technologically and has the greatest recording density with up to greater than 600 kilobytes of data storage not being uncommon. A typical format for a floppy disk is shown in Fig 8-2.

In almost all cases, digital data is first stored in the computer’s memory, usually RAM, then read to the disk out of this buffer memory. This action limits the speed in which data may be written to the disk. The data throughput is usually defined by how fast the read-write action can be accomplished between computer buffer memory and the disk drive.

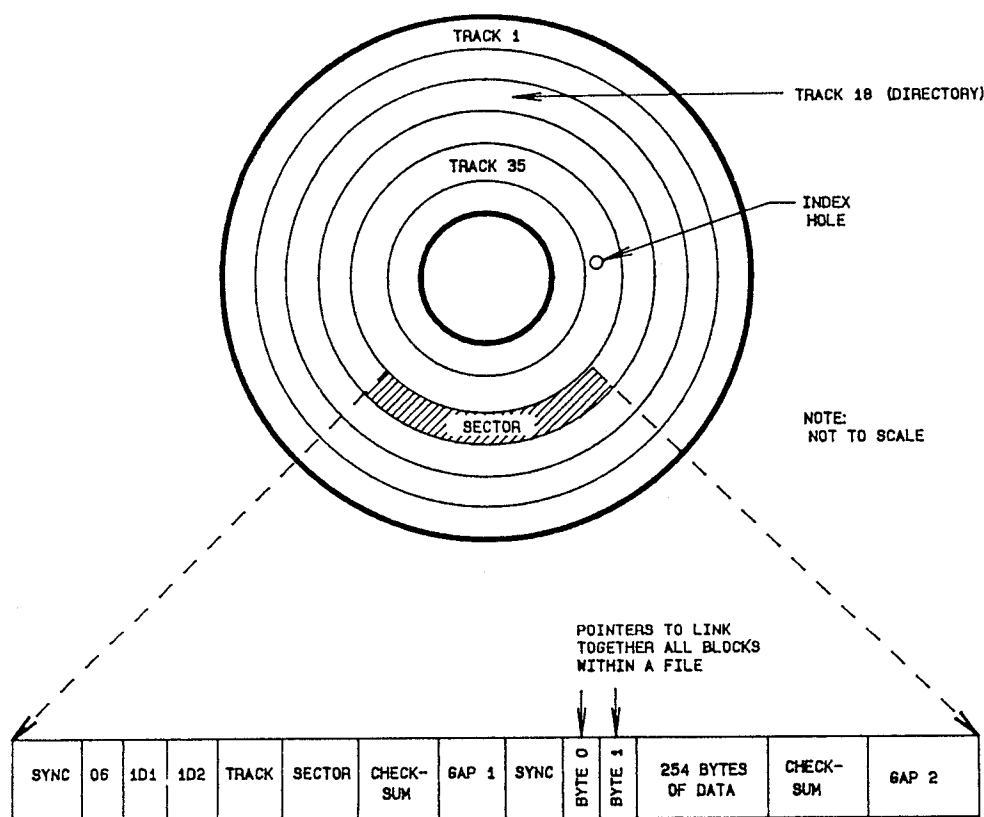

Figure 8-2—Typical Diskette Format Showing a Single Sector Expanded

Floppy disks or diskettes are an extremely versatile data storage medium. They are rugged, relatively insensitive to the environment, and may be mailed safely in inexpensive protective carriers. Recording densities have increased so that 5¹/₄-inch diskettes commonly contain 360 kilobytes of formatted data. New developments may double or triple those recording densities with major manufacturers now advertising data capacities in excess of 1.5 megabytes per diskette.

8.1.5 Data Analysis

Analysis of data acquired is the final step in computer-based data acquisition. No firm standards or methods exist presently; each end user of the data should decide how he/she wants to sort, analyze, and present the data. This correlation and/or analysis of data should be thought out prior to the actual implementation of the data acquisition system so that neither too little nor too much data is acquired. Each case (too little or too much data) presents problems

to the analysis portion of a project, and careful consideration of what is required from a particular measurement is very important when utilizing computer-based techniques and sampled data systems.

8.2 Optical Fibers in Instrumentation

8.2.1 Introduction

Immunity to electro-magnetic interference and dielectric construction make optical fibers ideal for use in electrically noisy environments. Driven by the communications industry, the cost of fibers has rapidly decreased, while the performance continues to improve. Coupled with a wide variety of sensors, they are finding increasing use in all types of instrumentation.

8.2.2 Sensors—Active Versus Passive

Conventional active sensors can be coupled to optical fibers to obtain isolation from a measurement point. However, active sensors require power supplies of some sort, a significant disadvantage in many inaccessible installations.

Passive sensors have been developed that make use of the optical properties of the fiber itself, or of special sensor materials. A brief description of passive optical techniques for measurement of various quantities follows.

8.2.3 Current

A material that exhibits the Faraday effect will change the polarization of a light beam passing through it parallel to an applied magnetic field.

An optical fiber that exhibits the Faraday effect can be wrapped around a current-carrying conductor to create a very simple passive current sensor. In practice, the design is somewhat more complicated by the need to minimize polarization changes due to vibration and temperature-induced stresses.

8.2.4 Voltage

The application of an electric field to a material exhibiting either the Pockels or Kerr effect produces a change in the optical polarization. For the Pockels effect this change is proportional to the electric field intensity, whereas with the Kerr effect, the change is proportional to the square of the electric field intensity.

A simple passive optical voltage sensor can be made using a lithium niobate crystal placed inside a high-voltage bus duct, because the electric field is well-defined. However, the electric field in the proximity of a conventional air-insulated high-voltage line does not lend itself to such a simple installation.

8.2.5 Temperature

One technique of measuring temperature optically uses a special phosphor at the tip of a fiber optic cable. After activating the phosphor with a pulse of ultraviolet light, the temperature of the phosphor is determined by measuring the decay times of specific wavelengths of light emitted from the phosphor. The tip of this device is small, and completely passive.

Another optical temperature-measuring technique uses infrared light radiated from an optical fiber cable itself. The temperature of a hot spot in a cable can be determined by measuring the wavelength of infrared light coming out of the end of the cable. If detectors are placed at both ends, the location of the hot spot can be determined by comparing the signal strengths.

8.2.6 Pressure

Microbending in a fiber optic cable increases the attenuation by causing some of the light to pass out of the core into the cladding. Squeezing a fiber between two corrugated surfaces can temporarily create a number of microbends, allowing the applied pressure to be measured.

A variation of this sensor has been made by jacketing an optical fiber in a wide-spaced spiral that presses alternately on one side of the optical fiber after the other.

8.2.7 Acceleration

A cantilever beam mounted at an angle to the end of a fiber optic cable will reflect varying amounts of the light coming out of the cable back into it. Completely passive accelerometers have been made in this way.

The above listed quantities and some of the techniques by which they can be measured are only an example of what is occurring in the field of optical measurement. New developments are occurring continuously, adding to those identified.

8.3 Bibliography

[1] *Fiber Optic Applications in Electrical Power Systems*. IEEE Tutorial Course, 84 EH0225-3-PWR, Dennis C. Erickson, Coordinator.

[2] *Fiber Optic Applications in Electrical Substations*. Joint report by the IEEE Microwave Radio Subcommittee and the Research Subcommittee of the Power System Communications Committee, 83 WM 025-4.